



PERFORMANCE RANGE

- Flow rate up to **80 l/min** (4.8 m³/h)
- Head up to **72 m**

APPLICATION LIMITS

- Manometric suction lift up to **9 m** (HS)
- Liquid temperature between **-10 °C** and **+40 °C**
- Ambient temperature up to **+40 °C**
- Max. working pressure **6.5 bar**
- Continuous service **S1**

CONSTRUCTION AND SAFETY STANDARDS

EN 60335-1
IEC 60335-1
CEI 61-150

EN 60034-1
IEC 60034-1
CEI 2-3



CERTIFICATIONS



INSTALLATION AND USE

Suitable for use with clean water and liquids that are not chemically aggressive towards the materials from which the pump is made. The self-priming JCR pumps are designed to pump water even in cases where air is present. As a result of their reliability and the fact that they are easy to use, they are recommended for use in domestic applications such as the distribution of water in combination with small or medium sized pressure sets, and for the irrigation of gardens and allotments, etc.

The pump should be installed in an enclosed environment, or at least sheltered from inclement weather.

PATENTS - TRADE MARKS - MODELS

- European Patent n° 1 510 696

OPTIONALS AVAILABLE ON REQUEST

- Other voltages or 60 Hz frequency

GUARANTEE

2 years subject to terms and conditions

CHARACTERISTIC CURVES AND PERFORMANCE DATA

50 Hz n= 2900 1/min HS= 0 m

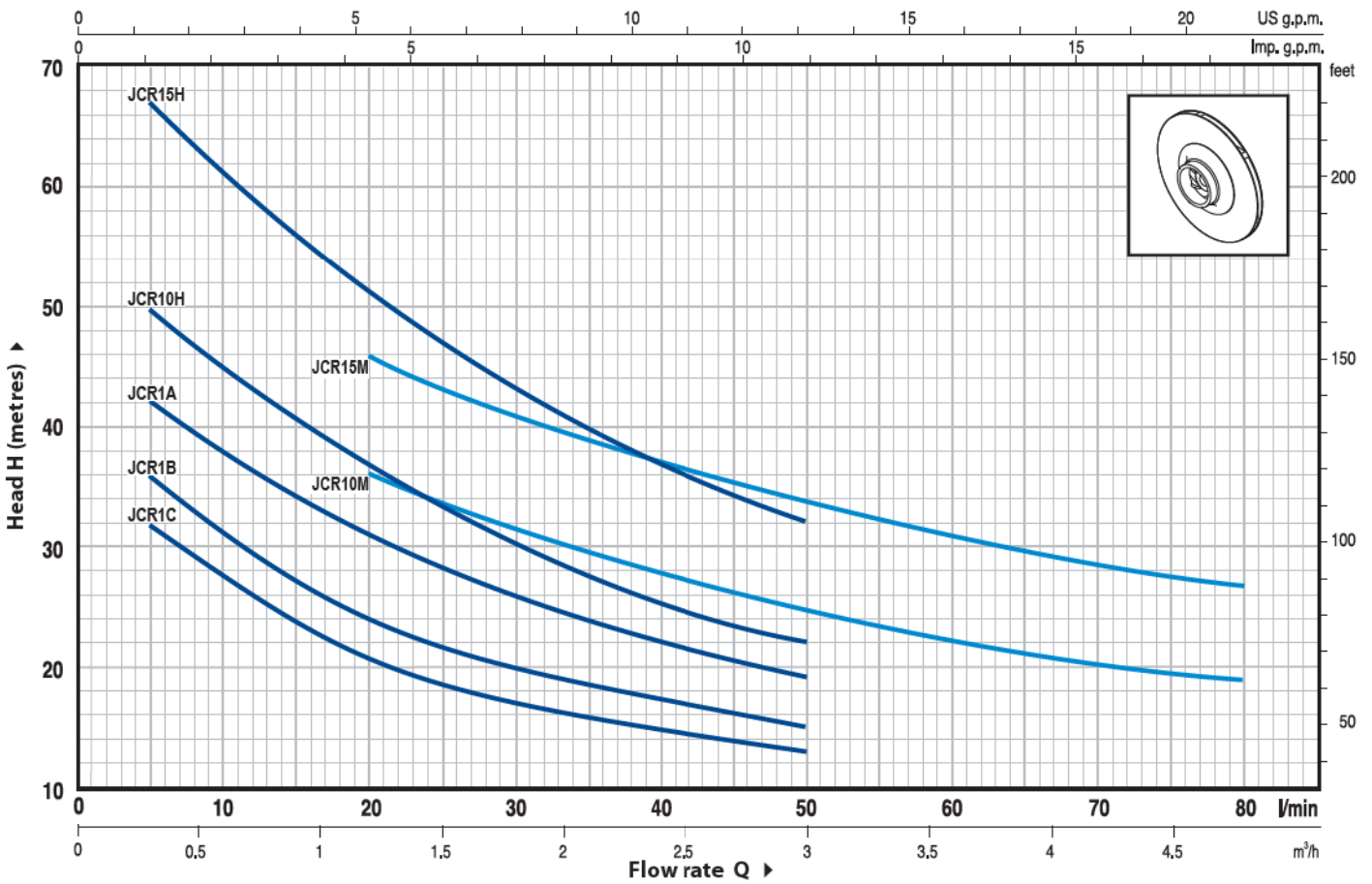

MODEL		POWER		Q	Flow rate															
Single-phase	Three-phase	kW	HP		m³/h	0	0.3	0.6	0.9	1.2	1.5	1.8	2.1	2.4	3.0	3.6	4.2	4.8		
				l/min	0	5	10	15	20	25	30	35	40	50	60	70	80			
JCRm 1C	-	0.37	0.50	H metres	35	32	27	24	21	19	17	16	15	13						
JCRm 1B	JCR 1B	0.50	0.70		41	36	31	27	24	22	20	19	17	15						
JCRm 1A	JCR 1A	0.60	0.85		47	42	38	34	31	28.5	26	24	22	19						
JCRm 10H	JCR 10H	0.75	1		56	50	45	41	37	33	30	27	25	22						
JCRm 15H	JCR 15H	1.1	1.5		72	67	61	56	51	47	43	40	37	32						
JCRm 10M	JCR 10M	0.75	1		46	44	41	39	37	35	32	30	28	25	22	21	19			
JCRm 15M	JCR 15M	1.1	1.5		55	53	50	48	46	43	41	39	37	34	31	29	27			

Q = Flow rate H = Total manometric head HS = Suction height

Tolerance of characteristic curves in compliance with EN ISO 9906 App. A.

INSTALLATION EXAMPLE

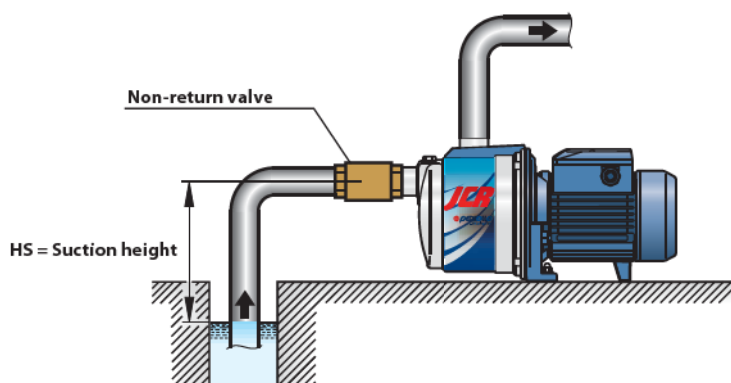

POS.	COMPONENT	CONSTRUCTION CHARACTERISTICS					
1	PUMP BODY	Stainless steel AISI 304, complete with threaded ports in compliance with ISO 228/1					
2	BODY BACKPLATE	Stainless steel AISI 304					
3	NOZZLE ASSEMBLY	Noryl GFN2V					
4	IMPELLER	Noryl GFN2V					
5	MOTOR SHAFT	Stainless steel EN 10088-3 - 1.4104					
6	MECHANICAL SEAL	<i>Pump</i>	<i>Seal</i>	<i>Shaft</i>	<i>Materials</i>		
		<i>Model</i>	<i>Model</i>	<i>Diameter</i>	<i>Stationary ring</i>	<i>Rotational ring</i>	<i>Elastomer</i>
		JCR 1C-B-A	AR-12	Ø 12 mm	Ceramic	Graphite	NBR
		JCR 10-15	AR-14	Ø 14 mm	Ceramic	Graphite	NBR
7	BEARINGS	<i>Pump</i>	<i>Model</i>				
		JCR 1C-B-A	6201 ZZ / 6201 ZZ				
		JCR 10H-M / 15H-M	6203 ZZ / 6203 ZZ				
8	CAPACITOR	<i>Pump</i>	<i>Capacitance</i>				
		<i>Single-phase</i>	<i>(230 V or 240 V)</i>	<i>(110 V)</i>			
		JCRm 1C	10 µF 450 VL	25 µF 250 VL			
		JCRm 1B	10 µF 450 VL	30 µF 250 VL			
		JCRm 1A	14 µF 450 VL	30 µF 250 VL			
		JCRm 10H-M	20 µF 450 VL	60 µF 300 VL			
JCRm 15H-M	25 µF 450 VL	60 µF 300 VL					
9	ELECTRIC MOTOR	<p>JCRm: single-phase 230 V - 50 Hz with thermal overload protector built-in to the winding. JCR: three-phase 230/400 V - 50 Hz.</p> <p>⇒ Pumps fitted with the three-phase motor option offer IE2 (IEC 60034-30) class high performance</p> <p>- Insulation: F class. - Protection: IP 44.</p>					

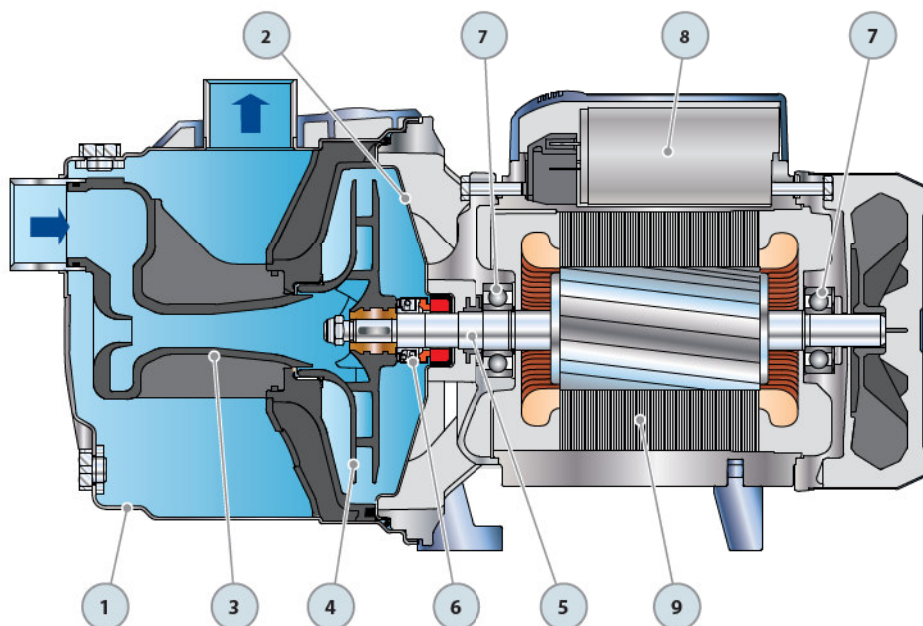

DIMENSIONS AND WEIGHT

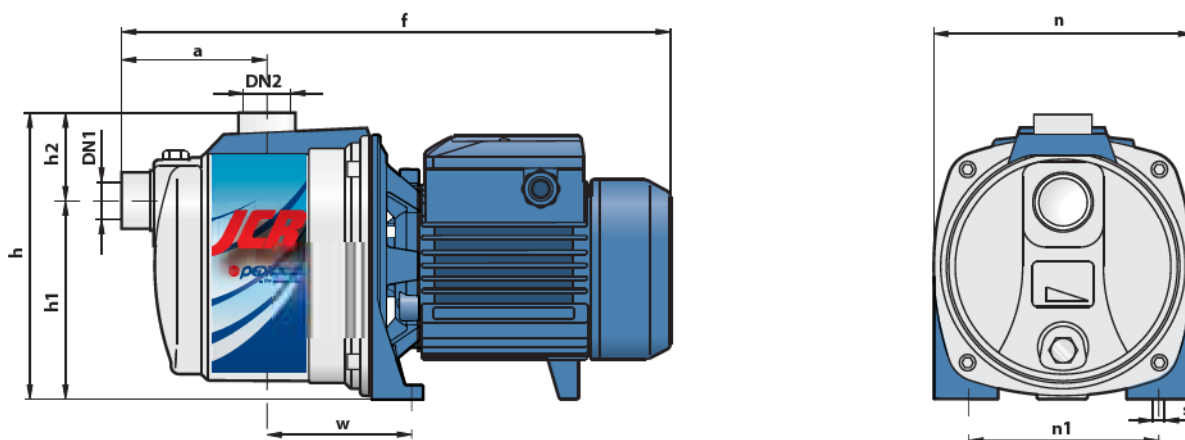

MODEL		PORTS		DIMENSIONS mm									kg	
Single-phase	Three-phase	DN1	DN2	a	f	h	h1	h2	n	n1	w	s	1~	3~
JCRm 1C	-												5.6	-
JCRm 1B	JCR 1B	1"	1"	90	345	174	122	52	160	120	88	9	6.4	6.3
JCRm 1A	JCR 1A												6.9	6.4
JCRm 10H-M	JCR 10H-M	1 1/4"	1"	117	406	206	145	55	184	135	110	10	9.4	9.3
JCRm 15H-M	JCR 15H-M												10.5	10.3

ABSORPTION

MODEL	VOLTAGE (single-phase)		
	230 V	240 V	110 V
JCRm 1C	2.4 A	2.2 A	4.8 A
JCRm 1B	3.2 A	2.9 A	6.5 A
JCRm 1A	3.6 A	3.3 A	7.3 A
JCRm 10H	4.7 A	4.5 A	9.4 A
JCRm 15H	6.6 A	6.0 A	13.2 A
JCRm 10M	5.0 A	4.6 A	10.0 A
JCRm 15M	6.6 A	6.0 A	13.2 A

MODEL	VOLTAGE (three-phase)					
	230 V	400 V	690 V	240 V	415 V	720 V
JCR 1B	2.1 A	1.2 A	0.7 A	2.0 A	1.2 A	0.7 A
JCR 1A	2.8 A	1.6 A	0.9 A	2.7 A	1.6 A	0.9 A
JCR 10H	3.5 A	2.0 A	1.2 A	3.4 A	2.0 A	1.2 A
JCR 15H	5.5 A	3.2 A	1.8 A	5.3 A	3.1 A	1.8 A
JCR 10M	3.6 A	2.1 A	1.2 A	3.5 A	2.0 A	1.2 A
JCR 15M	5.5 A	3.2 A	1.8 A	5.3 A	3.1 A	1.8 A

PALLETIZATION

MODEL		GROUPAGE				CONTAINER			
Single-phase	Three-phase	n° pumps	H (mm)	kg		n° pumps	H (mm)	kg	
				1~	3~			1~	3~
JCRm 1C	-	98	1440	570	-	154	2180	880	-
JCRm 1B	JCR 1B	98	1440	650	640	154	2180	1010	990
JCRm 1A	JCR 1A	98	1440	700	650	154	2180	1080	1010
JCRm 10H-M	JCR 10H-M	72	1460	700	690	96	1900	920	910
JCRm 15H-M	JCR 15H-M	72	1460	780	760	96	1900	1030	1010

