

Hydrolux



Bypass valves for thermostatic radiator valves system

Differential pressure overflow valve with direct setting value display

*Engineering
GREAT Solutions*

Hydrolux

Hydrolux is a proportional working, p-band controlled overflow valve with low proportional deviation.

Key features

- > Direct setting scale display
- > Low friction valve disc center guide
- > Low proportional deviation
- > Highest reaction precision due to an inner setting value spring with generous dimensions
- > Extremely low noise, current efficient construction



Technical description

Applications:

Heating and cooling systems.

Function:

Proportional relief
Adjustable differential pressure (Δp)

Dimensions:

DN 20-32

Pressure class:

PN 16

Setting range:

50–500 mbar (5–50 kPa).

Adjusted on the operating side and preset to 200 mbar (20 kPa).

300–1800 mbar (30–180 kPa).

Adjusted on the operating side and preset to 300 mbar (30 kPa).

Recommended max. volume flow (V):

DN 20: 2,0 m³/h

DN 25: 3,5 m³/h

DN 32: 7,0 m³/h

Max. heat flow (Q):

at Δt 20 K / 10 K

DN 20: 46,5 / 23,3 kW

DN 25: 81,4 / 40,7 kW

DN 32: 162,8 / 81,4 kW

Temperature:

Max. working temperature: 120°C

Min. working temperature: -10°C

Materials:

Body: Corrosion-resistant gunmetal

O-rings: EPDM

Valve disc: EPDM

Spring: stainless steel

Valve insert: Brass

Spindle: Brass

Handwheel: PA6.6 GF30

Pipe connection:

Female thread connections on the incoming side, female thread or flat sealing lockshield on the out going side.

Threads according to ISO 7/1 (DIN 2999).

Marking:

Body: THE, PN, DN and flow direction arrow.

Handwheel: Heimeier, DN

Construction

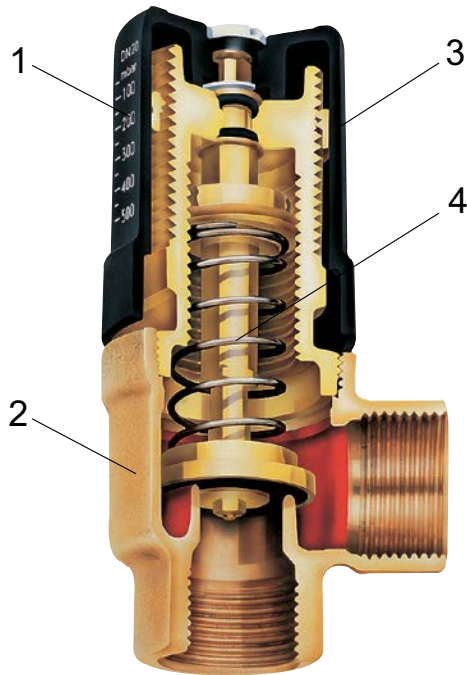

1. Setting scale
2. Body made of corrosion resistant gunmetal
3. Handwheel
4. Setting value spring

Function

The p-band which applies when the heating system is in full operation is set on the overflow valve.

When the current output is reduced, the valve opens, causing the output rate of the circulating pump to remain constant within a proportional band necessary for control purposes.

Application

Hydrolux is used in warm water pump heating systems. The current output of the circulating pump changes according to the heating load and operating condition of a heating system. Depending on the characterization of the pump characteristic line, a decrease in current output causes an increase in the output rate. In addition, the pressure loss in the pipe network decreases, creating the possibility of an oversupply and noise build-up in parts of the system.

The Hydrolux overflow valve prevents an undesirable increase in the output rate and ensures that the current output remains constant.

For gas fired wall mounted heating systems, the minimum circulating water level is guaranteed. We particularly recommend that an overflow valve be used when the maximum output rate is significantly greater than the set opening pressure.

To improve the effect of the overflow valve, the bypass connection should be set up in a current-efficient way, or in such a way that pressure loss is low, i. e. as short as possible, with generous dimensions and without unnecessary individual resistances.

Sample application

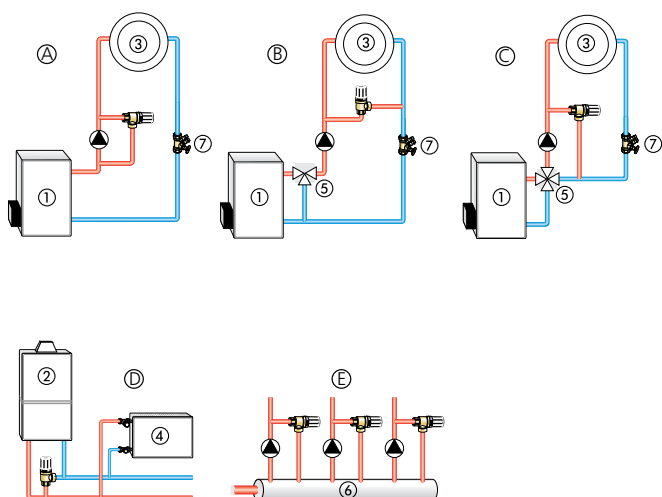

1. Oil/ gas boiler
2. Wall-mounted gas fired heater
3. Heating circuit
4. Radiator
5. 3-/4-way mixer
6. Manifold
7. STAD balancing valve

- A. System without mixer. Installed between the pressure and suction support pieces of the circulating pump.
- B. System with three-way mixer. Installed between the supply and return pipes.
- C. Heating system with fourway mixer. Installed between the supply and return pipes.
- D. Heating system with gas-fired wall mounted heater. Installed between the supply and return pipes (minimum circulating water level).
- E. System with several heating circuits. Installed between the supply pipe and the manifold.

Note

The contents of the heat transfer medium should comply with VDI guideline 2035 to prevent damage and scale deposit formation in warm water heating systems.

For industrial and long-distance energy systems, see the applicable codes VdTÜV 1466 and AGFW 5/15.

Mineral oils in the heat transfer medium or lubricants containing

mineral oils of any type lead to strong swelling and in most cases cause EPDM seals to fail.

When using nitrite-free frost and corrosion-resistance solutions with an ethylene glycol base, pay close attention to the details outlined in the manufacturers' documentation, particularly details concerning concentration and specific additives.

Setting

The Hydrolux overflow valve is adjustable on the operating side and is preset to an opening pressure of 200 mbar (2 m WS). In most cases, this value has proved to be effective. If, however, a change to the presetting is required, first loosen the fastening screw. Then the opening pressure can be changed progressively within a range of 50 mbar and 500 mbar. At the same time, the required value can be read directly off the scale on the handwheel.

No setting diagrams are required. The position selected should then be secured against unauthorized adjustment with the fastening screw.

Additionally there are models with a setting range of 300 mbar - 1800 mbar available. These are preset to an opening pressure of 300 mbar (30 kPa) on the operating side.

Diagrams

50-500 mbar

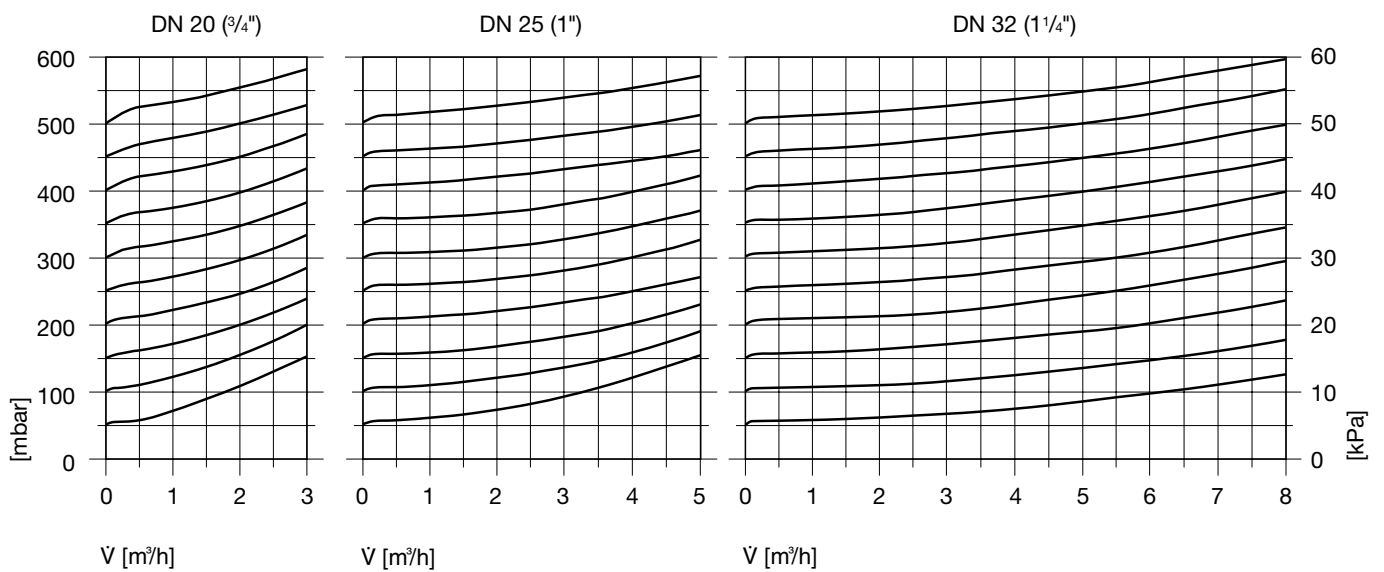

300-1800 mbar

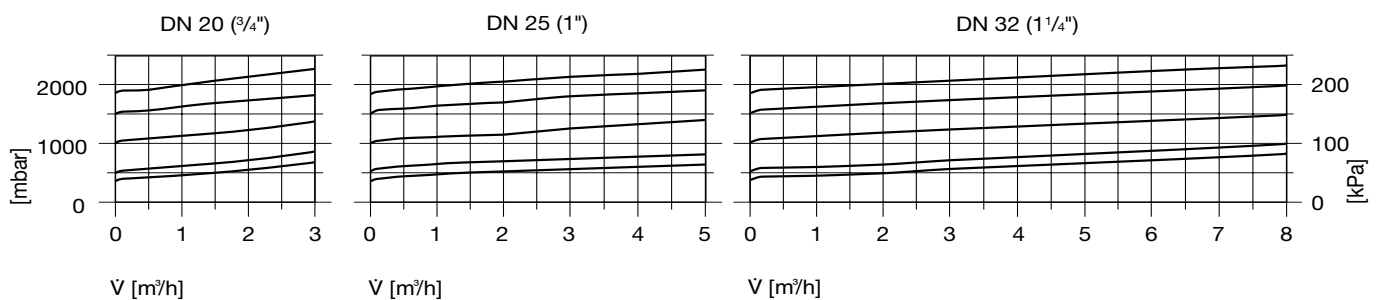

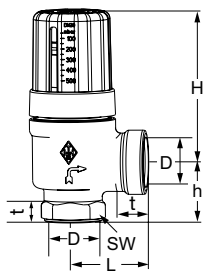
Articles setting range 50-500 mbar (5-50 kPa)

Sleeve female thread

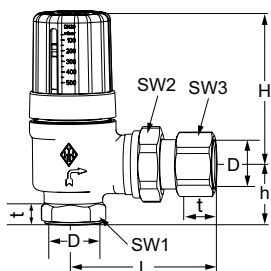
DN	D	L	H	h	SW1	Recommended max. volume flow V [m ³ /h]	EAN	Artikel-Nr.
20	Rp3/4	40	85	32	32	2,0	4024052239511	5501-03.000
25	Rp1	48	90	37	39	3,5	4024052239610	5501-04.000
32	Rp1 1/4	55	90	46	50	7,0	4024052239719	5501-05.000

Flat sealing wihht fitting

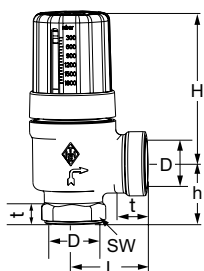
DN	D	L	H	h	SW1	SW2	SW3	Recommended max. volume flow V [m ³ /h]	EAN	Artikel-Nr.
20	Rp3/4	77	85	32	32	37	32	2,0	4024052240111	5503-03.000
25	Rp1	90	90	37	39	47	41	3,5	4024052240210	5503-04.000

Articles setting range 300-1800 mbar (30-180 kPa)

Sleeve female thread

DN	D	L	H	h	SW1	Recommended max. volume flow V [m ³ /h]	EAN	Artikel-Nr.
20	Rp3/4	40	85	32	32	2,0	4024052741519	5501-13.000
25	Rp1	48	90	37	39	3,5	4024052741618	5501-14.000
32	Rp1 1/4	55	90	46	50	7,0	4024052741717	5501-15.000

