

Superinox 60/50-24H

ŪDENS APGĀDES AUTOMĀTS

Pielietojums:

Paredzēts nelielu privātmāju, lauku sētu, saimniecības ēku, vasarnīcu apgādei ar ūdeni automātiskā režīmā, augļu un sakņu dārzu laistīšanai, automašīnu mazgāšanai.

Pielietojuma ierobežojumi:

1. Maksimālā sūkņejamā ūdens temperatūra +35°C.
2. Aizliegts sūkņēt jūras ūdeni, kā arī ķīmiski agresīvus un sprādzienbīstamus šķidrumus.
3. Sūkni nedrīkst darbināt tukšgaitā bez ūdens.
4. Sūkni jāapgādā ar elektrību.



Elektriskie dati:

- | | |
|-----------------------------------|-------------------|
| 1. Elektrodzinēja absorbētā jauda | P1- 0,8 kW |
| 2. Elektrodzinēja nominālā jauda | P2-0,55kW |
| 3. Vienfāzu maiņstrāvas spriegums | 220V/50Hz |

Sūkņa dati:

- | | |
|-------------------------------------|---|
| 1. Maksimālā ražība | līdz 55 l/min. (3,3 m³/h) |
| 2. Maksimālais spiediens | līdz 46m (4,6 atm.) |
| 3. Maksimālais uzsūkšanas augstums | 8 m |
| 4. Sūkņa pievienošanas vītņu izmēri | 1" F |
| 5. Svar | 12,7 kg |

Spiedkatls:

N-24 (nerūsējošais tērauds)
Tilpums

24 litri

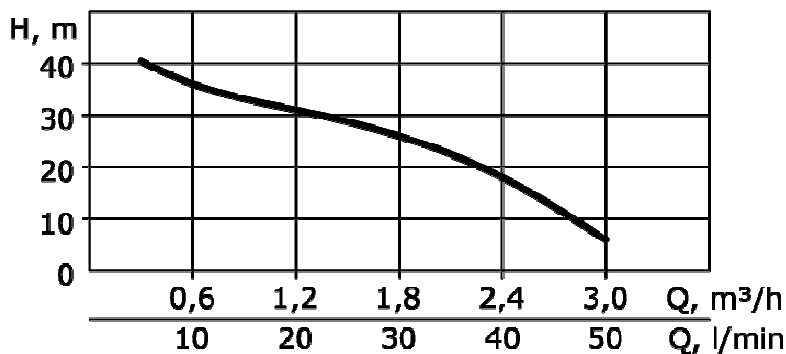

Sūknī izmantotie materiāli:

- sprausla, Venturi caurule, difuzors un lāpstiņu rats ir izgatavoti no norila;
- sūkņa korpuss no nerūsējošā tērauda;
- sūkņa ass ir izgatavota no nerūsējošā tērauda;
- starp sūkni un motoru ir grafitā-keramikas blīvslēgs;
- abpusēji slēgti lodīšu gultņi, kuros ir smērviela.

Garantija:

Ūdens automāta garantijas laiks ir **24 mēneši** no nopirkšanas dienas.

Garantijas darbnīca: "Akveduktī", Ķekavas pagasts, Ķekavas novads. Tālrunis: 67408116.

WATERPRESS SUPERINOX

PRESSURE BOOSTER SET WITH 24 LT HORIZONTAL PRESSURE TANK

The Pressure booster set WATERPRESS SUPERINOX are made with a JETINOX self-priming centrifugal pump. They are supplied wired and complete with a stainless steel pressure tank.

APPLICATIONS

- Lifting and distribution of water in domestic systems
- Pressurization systems.
- Washing and irrigation.

CONSTRUCTION FEATURES

- Pressure switch (max 6 bar) set at: min 2 ÷ max 3 bar.
- Pressure gauge (6 bar).
- 5-way moulded brass plated connector.
- 24 Lt pressure tank in stainless steel with interchangeable rubber membrane for food.
- Tuboflex hydraulic connection.
- Power cable 1.5 m H05 RN-F with plug

USAGE DATA

- Type of liquid: clean water without suspended solids or abrasive material.
- Maximum temperature of the liquid 50°C.
- Maximum intake height recommended with foot valve. 8 m WP Superinox 60/50
- Maximum operating pressure: 6 m WP Superinox 60/50

MOTOR

- Closed, ventilated from outside.
- Degree of protection IP 44.
- Insulation class F.
- Single-phase power supply with capacitor always on.
- Thermal protection built into the motor casing.
- Speed of rotation 2850 rpm.
- Continuous service.



TABLE OF MATERIALS

Component	Material
	WP SUPERINOX 60/50
Pump body	Stainless steel X5 CrNi 1810 (AISI 304)
Motor casing	Die-cast aluminium
Impellers	Technopolymer with stainless steel shim ring
Diffuser-Venturi tube-nozzle	Technopolymer
Shaft	Stainless steel X 12 CrNiS 1809 (AISI 416)
Mechanical seal	Graphite
Counterface	Ceramic
Seal holder plate	Technopolymer
Gaskets	NBR 70 shore

WATERPRESS SUPERINOX

PRESSURE BOOSTER SET WITH 24 LT HORIZONTAL PRESSURE TANK

HYDRAULIC PERFORMANCE

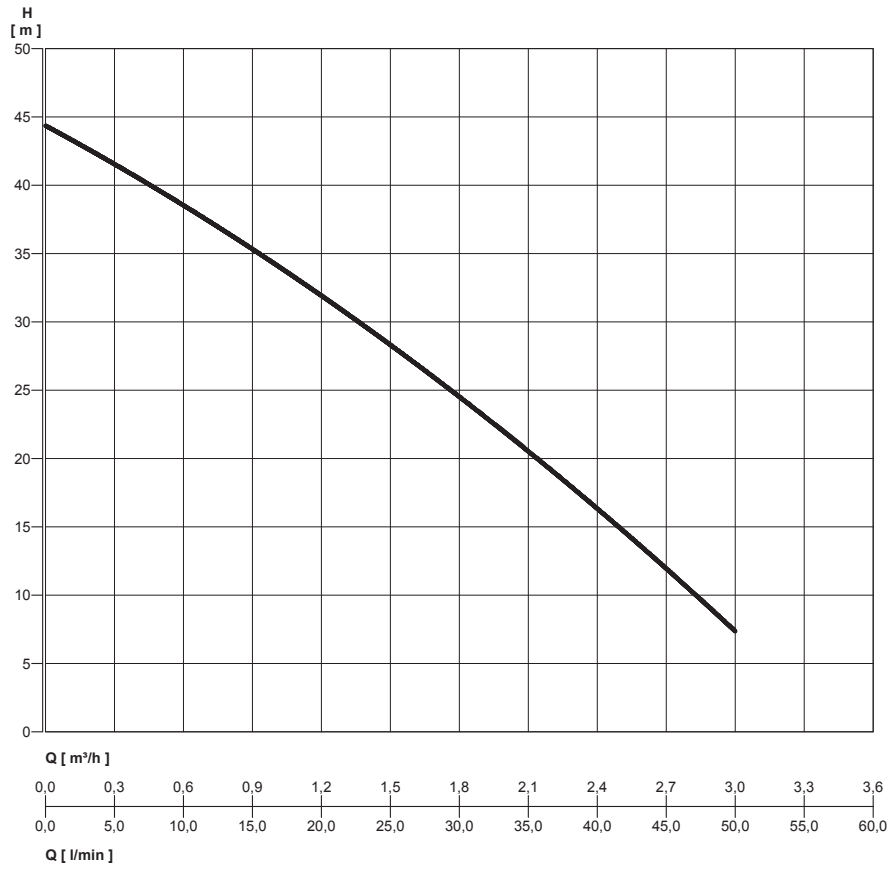

PERFORMANCE TABLE

MODEL	Motor power (P2)		Motor power (P1)		VOLT (V)	In (A)	μF	0	m.c.w.						
	HP	kW	HP	kW					l/min	0	10	20	30	40	50
									m³/h	0	0,6	1,2	1,8	2,4	3
WP SUPERINOX 60/50 C JET	0,75	0,55	1,1	0,8	1~230	4	12,5		46	36	31	26	18	6	

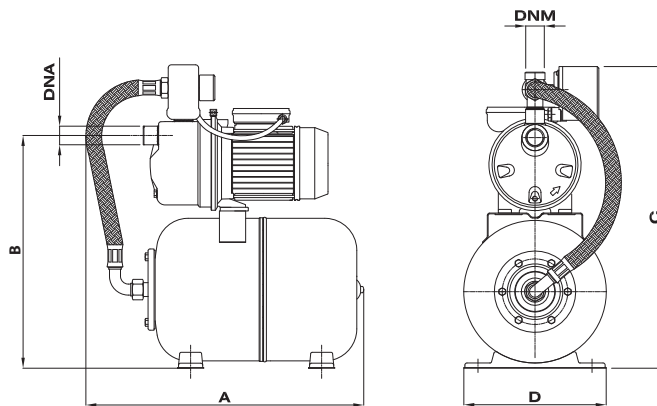

OVERALL DIMENSIONS AND WEIGHTS

MODEL	Dimensions mm.						WEIGHT (Kg)
	A	B	C	D	DNA	DNM	
WP SUPERINOX 60/50 C	530	425	550	280	1" F	1" F	11,2