

SADDLE FOR PE/PVC PIPES series BPE



APPLICATION

BLUCAST saddles for PE/PVC are easy to mount, maintenance free and designed for long life.

TECHNICAL CHARACTERISTICS

Maximum working pressure: PN16 / 16 bar

Working temperature: 0°C - +70°C

Color RAL5015

Powder epoxy coating 250 µm thickness

TAPPING SADDLES

DN	DE	G	Lenght	H	Weight	BLUCAST ref. no.
DN50	50	1"	100	84	0.8	BPE0501
DN50	50	1 1/4"	100	84	0.8	BPE050114
DN50	50	1 1/2"	100	84	0.8	BPE050112
DN63	63	1"	100	97	1.2	BPE0631
DN63	63	1 1/4"	100	97	1.2	BPE063114
DN63	63	1 1/2"	100	97	1.2	BPE063112
DN63	63	2"	100	97	1.2	BPE0632
DN75	75	1"	100	111	1.35	BPE0751
DN75	75	1 1/4"	100	111	1.35	BPE075114
DN75	75	1 1/2"	100	111	1.35	BPE075112
DN75	75	2"	100	111	1.35	BPE0752
DN90	90	1"	100	124	1.7	BPE0901
DN90	90	1 1/4"	100	124	1.7	BPE090114
DN90	90	1 1/2"	100	124	1.7	BPE090112
DN90	90	2"	100	124	1.7	BPE0902
DN110	110	1"	110	148	2.3	BPE1101
DN110	110	1 1/4"	110	148	2.3	BPE110114
DN110	110	1 1/2"	110	148	2.3	BPE110112
DN110	110	2"	110	148	2.3	BPE1102
DN160	160	1"	125	209	5	BPE1601
DN160	160	1 1/4"	125	209	5	BPE160114
DN160	160	1 1/2"	125	209	5	BPE160112
DN160	160	2"	125	209	5	BPE1602
DN200	200	1"	125	251	8.5	BPE2001
DN200	200	1 1/4"	125	251	8.5	BPE200114
DN200	200	1 1/2"	125	251	8.5	BPE200112
DN200	200	2"	125	251	8.5	BPE2002
DN250	250	2"	168	351	13	BPE2502
DN315	315	2"	195	385	17.5	BPE3152

No.	Item	Material
1	Body	Ductile iron EN-GJS-500-7
2	Gasket	EPDM
3	Bolts	AISI304 stainless steel

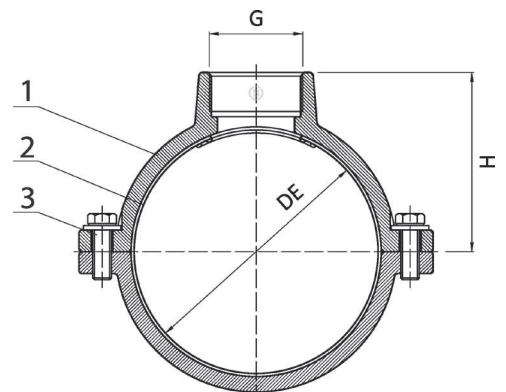

All illustrations, technical data, dimensions (in mm) and weights (all weights specified in kg) are non-binding and are subject to change

