

PN16 VALVE WEDGE WITH INNER THREAD AND OUTER-INNER THREAD

Application

Water intended for human consumption. In industrial installations, sewage systems and installations of other chemically inert liquids.

Admission

The State Hygiene Institute in Warsaw.

Technical Data

Working pressure PN16
 Max temp. 40 st C
 Flange connection in accordance with PN-EN ISO 228-1
 The maximum closing moment $MOT = 1 \times DN$ [Nm].
 Requirements and tests according to PN-EN 1074 -1 and 2

Design features

- A full, smooth and free of depression passage.
- It is possible to replace the valve stem gasnet under full pressure at any wedge position.
- Connections with internal and external thread G1", G1 1/2" and G1 1/4", G2".
- Brass nut of the bolt shaft seal (replaceable) protected against unscrewing the stainless steel ring, placed inside the cover under top gasket.
- Body and cover made of ductile cast iron EN-GJS 500-7.
- Stainless steel mandrel with thread rolled, in the sealing zone free of cuts, enabling cooperation with orings in the screw.
- Wedge made of ductile iron (for DN25 and DN32 made of brass) vulcanized inside and outside with EPDM or NBR rubber with a hardness of 70° Sh. grooved tongue in the bolt hull.
- Static gaskets made of EPDM rubber, dynamic from NBR rubber.
- The wedge nut mounting on the stem- non-replaceable, made of brass, ironed in a latch valve.
- Screws connecting the cover to the hull - threaded blinds, completely protected against corrosion with paraffin wax.
- Secured either internal and external against corrosion with epoxy powder paint RAL 5005 with a thickness of min. 250µm and resistance for a 3kV puncture



Pn16 valve wedge with inner thread

DN	H	L	I	K	S	G	mass (kg)	catalog number
25	185	96	17	12	55	1"	2,7	2642
32	185	96	17	12	55	1 1/4"	2,6	2650
40	220	160	20	14	60	1 1/2"	5,8	2660
50	235	175	25	14	75	2"	7,1	2670

No	Part	Materials
1	Stem	stainless steel 1.4021
2	Cover	ductile cast iron EN-GJS 500-7
3	Body	ductile cast iron EN-GJS 500-7
4	Gasket	EPDM/NBR rubber
5	Protecting ring	stainless steel 1.4301
6	Plug	brass
7	O-ring	EPDM/NBR rubber
8	O-ring	EPDM/NBR rubber
9	Bottom washer	Pollamid PA6
10	Cover screw	EPDM/NBR rubber
11	Bottom seal	galvanized or stainless steel
12	Stopping nut	brass
13	Cover gasket	EPDM/NBR rubber
14	Nut	brass
15	Wedge	ductile cast iron EN-GJS 500-7 EPDM/NBR rubber
16	DN32 wedge	brass EPDM/NBR rubber

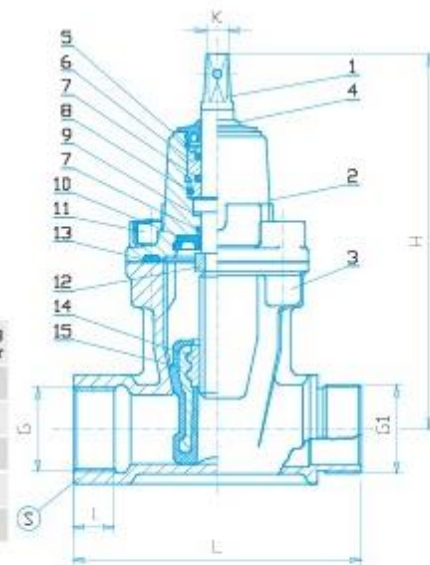
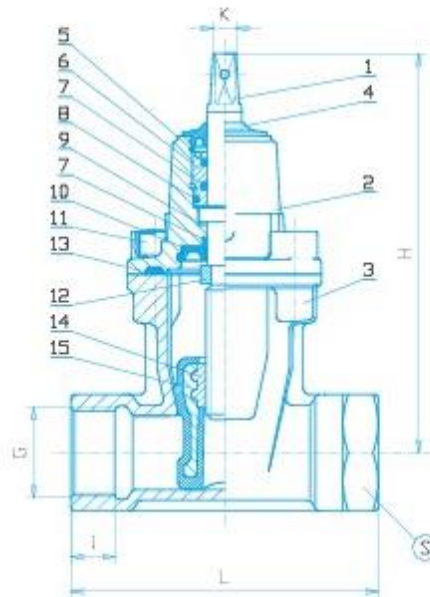
PN16 valve wedge with outer-inner thread

DN	H	L	I	K	S	G1	G	mass (kg)	catalog number
25	185	133	17	12	55	1 1/4"	1"	2,8	2643
32	185	133	17	12	55	1 1/4"	1 1/4"	2,8	2655
32	185	133	17	12	55	2"	1 1/4"	2,9	2656
40	220	168	20	14	60	2"	1 1/2"	5,9	2665
50	235	175	25	14	75	2"	2"	7,0	2675