



DISPENSERS



PUMPS



METERS



NOZZLE



FILTRATION



FLUID MONITORING

ST WITH METER

FEATURES

- **READY TO USE**
- **EASY TO INSTALL**
- **STURDY STRUCTURE**
- **HIGH PRECISION METER**
- **AVAILABLE WITH DIFFERENT PUMPS**

The PIUSI ST WITH METER is a diesel transfer station for fixed installations composed by AC or DC pump, nozzle (manual or automatic) and precision meter - both mechanical (K33) or electronic (K600/3 B) - for safe and controlled refueling operations. Easy to install, this station can be used to fill mobile tanks or interact with distribution units.

PERFORMANCE

UP TO

90 L/MIN

FLOW-RATE

AC/DC

VOLTAGE

POWER

± 1%

ACCURACY

4MT

LENGTH

DELIVERY HOSE



ST WITH METER



METALLIC BOX (optional)



PACKAGING

CODE	WEIGHT		PACKAGING		
	KG	LBS	MM	INCH	PCS/BOX
FO0385POA	16	35	357X357X275	14,1X14,1X10,8	1
FO0287POA	16	35	357X357X275	14,1X14,1X10,8	1
000390000	21	46	357X357X275	14,1X14,1X10,8	1
000392000	23	50	357X357X275	14,2X14,2X11,8	1
000395000	23	50	480X370X265	18,9X14,6X10,4	1
000395050	24	53	480X370X275	18,9X14,6X11,8	1
000397000	20	44	480X370X265	18,9X14,6X10,4	1
000256000	10	22	357X357X275	14,1X14,1X10,8	1
000287P40	19	41	357X357X275	14,1X14,1X10,8	1
FO023500B	13	29	357X357X275	14,1X14,1X10,8	1
FO023600B	13	29	357X357X275	14,2X14,2X11,8	1
FO023300B	14	31	480X370X265	18,9X14,6X10,4	1
FO023400B	14	31	480X370X265	18,9X14,6X10,4	1
FO024000A	24	53	357X357X275	14,1X14,1X10,8	1
FO024003A	24	53	357X357X275	14,1X14,1X10,8	1
FO024100A	24	53	357X357X275	14,1X14,1X10,8	1
FO024101A	11	11	357X357X275	14,1X14,1X10,8	1
FO0340070	17	37	357X357X275	14,1X14,1X10,8	1
FO0340160	17	11	357X357X275	14,1X14,1X10,8	1



HOSE REELS



ACCESSORIES



MERCHANDISE



AIR



ANTIFREEZE



AdBlue®



BIODIESEL



DIESEL



FOOD



GASOLINE



GREASE



KEROSENE



OIL



WATER



WINDSCREEN

AVAILABLE WITH DIFFERENT PUMPS

AC PUMP - PANTHER 56/72



AC PUMP - E80/E120



AC PUMP - VISCOMAT 70/90



DC PUMP - BYPASS 3000



DC PUMP - PANTHER DC



DC PUMP - BIPUMP

IN THE BOX

- ST UNIT
- METER
- DELIVERY HOSE
- NOZZLE
- NOZZLE HOLDER
- INSTRUCTION MANUAL

DETAILS

K33



MAN. / AUTOM. NOZZLE

COMPONENTS

- **PUMP:**
 - PANTHER AC PAG. 64
 - E80/E120 PAG. 68
 - VISCOMAT VANE PAG. 66
 - BP3000 PAG. 74
 - PANTHER DC PAG. 78
 - BIPUMP PAG. 80
- **NOZZLE:**
 - MANUAL NOZZLE PAG. 122
 - AUTOMATIC NOZZLE PAG. 118
- **METER:**
 - K33 PAG. 108

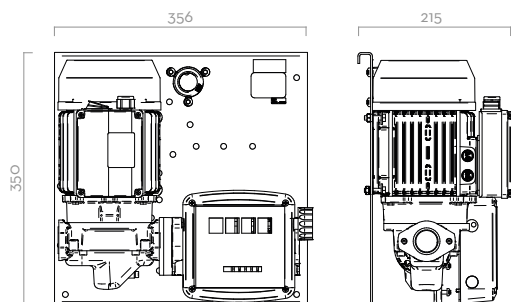
DIMENSIONSDimensions expressed
in millimeters**TECHNICAL DATA**

CODE	DESCRIPTION	FLUIDS TYPE	FLOW-RATE		VOLTAGE			METER	NOZZLE	INLET
			L/MIN	GPM	AC V/HZ DC VOLT	POWER WATT	AMP. MAX.			
FO0385POA	ST PANTHER 56 K33	D	56	15	230/50	350	3	K33	MAN.	3/4"
FO0287POA	ST PANTHER 56 K33 A60	D	56	15	230/50	350	3	K33	AUT.	3/4"
000390000	ST E80 K33	D	80	21	230/50	700	3,5	K33	MAN.	1"
000392000	ST E80 K33 A80	D	75	20	230/50	700	3,5	K33	AUT.	1"
000395000	ST E120 K33	D	90	24	230/50	1150	5,7	K33	MAN.	1"
000395050	ST E120/M K44	D	90	24	230/50	1150	5,7	K44	MAN.	1"
000397000	ST E120 K33 A120	D	90	24	230/50	1150	5,7	K33	AUT.	1"
000256000	ST VISCOMAT 70 K33 (RAPSOIL)	B	30	8	230/50	950	4,6	K33	MAN.	1"
000287P40	ST PANTHER 72/M K33 A80	D	72	19	230/50	500	4,2	K33	AUT.	1"
FO023500B	ST BYPASS 3000/12V K33	D	40	10	12	260	22	K33	MAN.	3/4"
FO023600B	ST BYPASS 3000 INLINE 24V K33	D	40	10	24	300	12	K33	MAN.	3/4"
FO023300B	ST BYPASS 3000/12V K33 A60	D	35	9	12	260	22	K33	AUT.	3/4"
FO023400B	ST BYPASS 3000 INLINE 24V K33 A60	D	35	9	24	300	12	K33	AUT.	3/4"
FO024000A	ST BI-PUMP 12V K33 SELF 3000	D	80	21	12	530	44	K33	MAN.	1"
FO024003A	ST BI-PUMP 12V K33 A120	D	80	21	12	530	44	K33	AUT.	1"
FO024100A	ST BI-PUMP 24V K33 SELF 3000	D	80	21	24	540	22,5	K33	MAN.	1"
FO024101A	ST BI-PUMP 24V K33 A120	D	80	21	24	540	22,5	K33	AUT.	1"
FO0340070	ST PANTHER 12V K33 A60	D	56	15	12	420	35	K33	AUT.	3/4"
FO0340160	ST PANTHER DC 12/24V K33 A60	D	70/35	18,5/9,2	24/12	420/150	25/16	K33	AUT.	3/4"

ST WITH METER