



DISPENSERS



PUMPS



METERS



NOZZLE



FILTRATION



FLUID
MONITORING

CONNECTORS

FEATURES

- STURDY STRUCTURE
- READY TO USE
- SEVERAL SOLUTIONS AVAILABLE

The range of fuel products is completed with a wide array of accessories for connecting products to allow the best performance. Starting form the 2" connectors and quick coupling.

PERFORMANCE

2"

DRUM CONNECTOR

2"

QUICK COUPLING



2" DRUM CONNECTOR WITHOUT INTEGRATED VALVE



2" DRUM CONNECTOR WITH FLANGED AND INTEGRATED VALVE



2" DRUM CONNECTOR WITH INTEGRATED VALVE



2" QUICK COUPLING



PACKAGING

CODE	PACKAGING			
	KG	MM	INCH	PCS/BOX
2" CONNECTOR				
F17163000	0,6	133X98X85	-	1
F17190000	0,6	133X98X85	-	1
F17163010	0,8	133X98X85	-	1
2" QUICK COUPLING				
RO9160000	0,9	133X98X85	-	1
RO8930000	0,9	133X98X85	-	1



HOSE REELS



ACCESSORIES



MERCHANDISE



AIR



ANTIFREEZE



AdBlue®



BIODIESEL



DIESEL



FOOD



GASOLINE



GREASE



KEROSENE



OIL



WATER



WINDSCREEN

CHART

EXTENSIBLE SUCTION STEEL KIT (1800MM) COMPOSED BY:

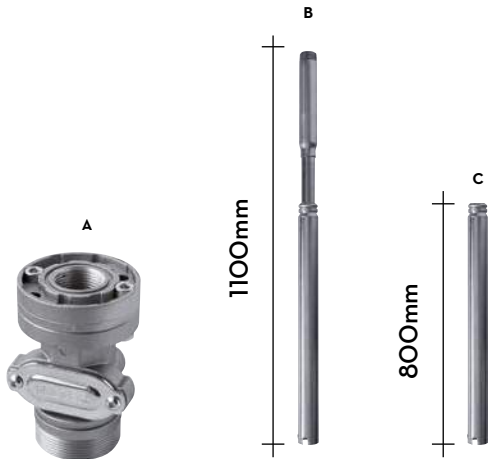

A:
DRUM CONNECTOR
FLANGED AND VALVE

B:
EXTENSIBLE STEEL
PIPE 1" BSP

C:
STEEL PIPE 1" BSP

CODE:
FOO8934010

WEIGHT:
3,9 KG

PACKAGING:
820X150X100

IN THE BOX

- CONNECTOR
- INSTRUCTION MANUAL

DETAILS



MESH STRAINER



INTEGRATED VALVE

DIMENSIONS

EXTENSIBLE PIPE PLASTIC MADE

EXTENSIBLE STEEL PIPE 1" BSP

2" CONNECTOR

2" QUICK CONNECTOR

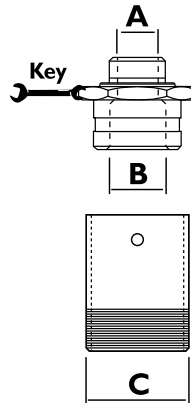
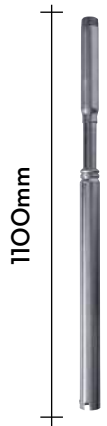
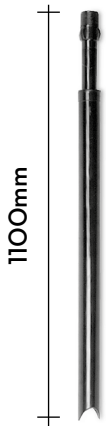

Dimensions expressed in millimeters

MATERIALS

- STEEL

TECHNICAL DATA

CODE	DESCRIPTION	FLUIDS TYPE	INTEGRATED VALVE	FILTER	INLET BSP	OUTLET BSP	THREADED FLANGE BSP	A	B	C	D	KEY
								BSP	BSP	BSP	MM	
2" CONNECTOR												
F17163000	DRUM CONNECTOR WITH INTEGRATED VALVE	D G K O	YES	YES	2"	-	NO	1"	1"	2"	62	-
F17190000	DRUM CONNECTOR WITHOUT INTEGRATED VALVE	D G K O	NO	YES	2"	-	NO	1"	1"	2"	62	-
F17163010	DRUM CONNECTOR WITH FLANGED AND INTEGRATED VALVE	D G K O	YES	YES	2"	1"	YES	1"	1"	2"	62	-
2" QUICK COUPLING												
RO9160000	QUICK COUPLING 3/4"	D O	NO	NO	3/4"	1"	NO	M 3/4"	F 1"	M 2"	1	60
RO8930000	QUICK COUPLING 1"	D O	NO	NO	1"	1"	NO	M 1"	F 1"	M 2"	1	60