



ABO

GRIP THAT HOLDS



Lloyds Register

DVGW

CE

SERIES 900

- // PN 6/10/16/Class 150
- // DN 32 - 1600 (1" ¼ - 64")
- // Industrial applications
- // Water, chemicals, gas
- // Oil & gas, air



RESILIENT SEATED BUTTERFLY VALVES

WWW.ABOVALVE.COM

GENERAL INFORMATION

GENERAL CHARACTERISTICS

- Concentric design
- Shut-off and regulating device
- Splitted shaft
- Pivot fixed by screw allows demounting (demountable version)
- Long neck of the body according to Heating Systems Regulation standards
- Orange epoxy painting RAL 2002 - 80 µm
- Vacuum max 0,2 bar absolute (with bonded liner)
- Movement of disc ensured by four-squared endstem
- Certificate ATEX (Group II, Category 1/2 GD TX)
- Approved for GAS and potable water applications by DVGW certification

APPLICATIONS

Butterfly valves series 900 are suited for many applications where tight shut-off is required, such as:

- Industrial Processing
- Water and Wastewater
- Dry Bulk Conveying
- Light Slurry Handling
- Paper Mills
- Food and Beverage
- HVAC (Heating, Ventilating & Air Conditioning)
- Non-mining environments and explosive atmosphere consisting of dust and gas (zones 0, 1, 20 and 21)

STANDARDS

LEAK TEST:

- EN 12266-1, Rate A
- ISO 5208, Rate A
- API 598, TAB. 5

FACE TO FACE:

- EN 558, SERIES 20
- ISO 5752, SERIES 20
- API 609, TAB. 2

TOP FLANGE:

- EN ISO 5211

CONNECTION

BETWEEN FLANGES:

- EN 1092-1
- DIN 2631
- ASME B16.5

WORKING STANDARD:

- EN 593 + A1

TYPE DESIGNATION

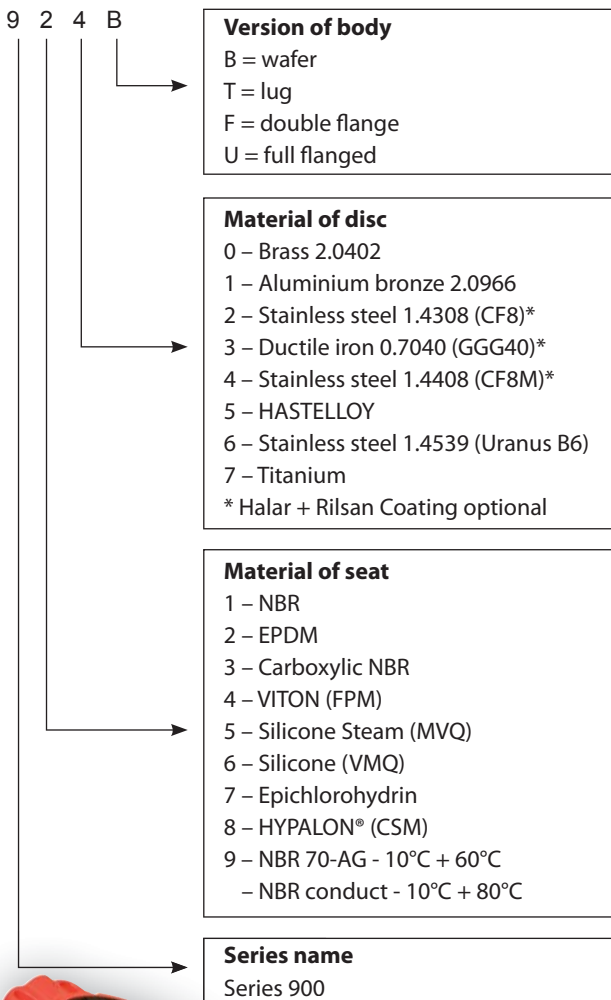

Models

Wafer type B



Lug type T



Double flanged type F
 for DN 700 – DN 1600



PRODUCT QUALITY AND CONTROL

- ABO production facilities are certified in accordance to ISO 9001 (14001, 18001) quality system
- Test procedures are established according to: EN 12266-1, ISO 5208, API 598, ANSI/FCI 70-2
- Manufacture according to the requirements of the European Directive 97/23/CE – Equipment under pressure (Category III, modul B)
- All ABO valves pass pressure tests to 110% of rated pressure to ensure bubble tight shutoff
- All actuators are calibrated and cycle tested before shipment
- Material Traceability Rule – Certification is provided for all supplied valves as per customer's request
- Positive Material Identification
 – All materials are subjected to PMI testing in order to verify Material Traceability Certificate
- Certificates - Complete list of certificates can be found on www.abovalve.com



DESIGN BENEFITS

1) INTERNATIONAL STANDARD COMPATIBILITY

Top flange according to Standard ISO 5211 enables direct mounting of manual operators and power actuators. Longer necks of ABO butterfly valves result in insulation of ISO top flange (protection of mounted actuator) and meeting Heating Systems Regulation standards.

2) BLOW-OUT PROOF SHAFT SYSTEM

No up-movement of the shaft is ensured by safety retainer in the body neck.

3) 2-PIECED SHAFT SYSTEM

The divided shaft-pivot system with a highly profiled disc ensure high Kv/Cv and lower pressure drop.

4) DOUBLE-SIDED PROFILES

Double-sided profiles ensure proper alignment of the sleeve in the outer body recess.

7) SEAT DESIGN

The seat is anchored in the body (groove and tongue design), and its movement is ensured by four-squared end stem.

5) FORMING LOBE

Liner stability is secured by a forming lobe, which fits perfectly into the relevant groove of the body.

6) DEMOUNTABLE VALVE DESIGN

ABO series 900 design allows for demounting and easy seat replacement.

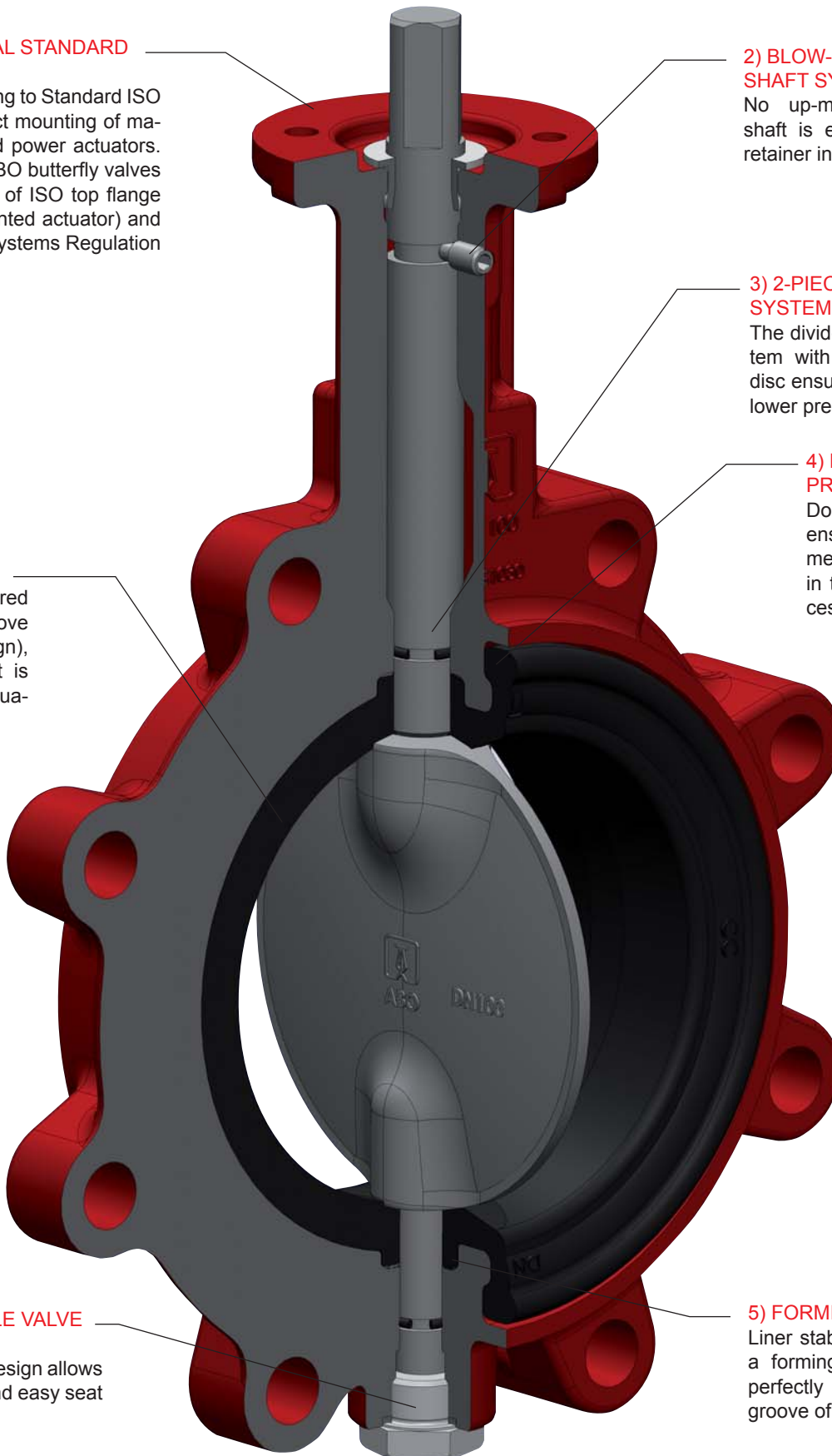

DESIGN BENEFITS

1) 3-STAGE SEALING SYSTEM

A triple safety feature system of sealing security designed by ABO engineers provides for a 100% tight shut-off, long term product life, and a safe mode of operation in the most demanding applications.

1. **Primary sealing** – Sealing surface of the seat in the contact area with both, the stem and the pivot respectively, has a precisely defined spherical geometry, which exactly replicates the geometry of the disc.
2. **Secondary sealing** – The secondary sealing feature is being created by stem (pivot) overlap in relation to the seat bore diameter.
3. **Tertiary sealing** – ABO series 900 butterfly valves are equipped with safety O-rings that further improve product operational performance and its reliability.

2) OPTIONS OF SEAT ANCHORING

1. **GROOVE AND TONGUE VERSION** – classical European design of groove and tongue anchoring prevents movement of the seat, yet at the same time, allows for material interchangeability and easy seat replacement.
2. **VULCANIZED SEAT VERSION** – vulcanized seat option is available for high vacuum applications or for under pressure conditions. For lower vacuum applications, a glued-seat version option is also available.

3) EXTERNAL COATING OPTIONS

1. **HIGH QUALITY EPOXY COATING** – ABO standard coating option is premium quality epoxy grade C2 with minimal thickness of 80 microns (EN12904-1).
2. **MARINE COATING** – marine coating for highly abrasive media especially in marine environment is an option. Grades C3, C4 and C5 are available.
3. **RILSAN 11 COATING** – Rilsan 11 coating provides superb corrosion resistance. This coating option is recommended for applications such as seawater, cement, food or water service contaminated with chemicals.
4. **AMERLOCK COATING** – Amerlock operator coating provides superior protection in the sea water environment.

4) SPECIAL PURPOSE VALVES

1. ALUMINIUM BODY VALVES FOR SWIMMING POOLS

ABO series 900 butterfly valves with body made out of aluminum, are due to lower weight, ideal for usage in applications where plastic piping is required. This valve design is especially suitable for swimming pool water applications.

- DN 50 up to DN 200
- 3 bar maximum working pressure
- -10C up to +100C

2. ALUMINIUM BRONZE BODY VALVES FOR MARINE SERVICE

ABO offers high quality resilient-seated butterfly valves fully from Aluminum bronze material to meet the requirements of today's industrial/marine markets. These valves are specifically designed for onshore and offshore service where maximum product reliance is required in an extremely abrasive environment with high levels of salinity.

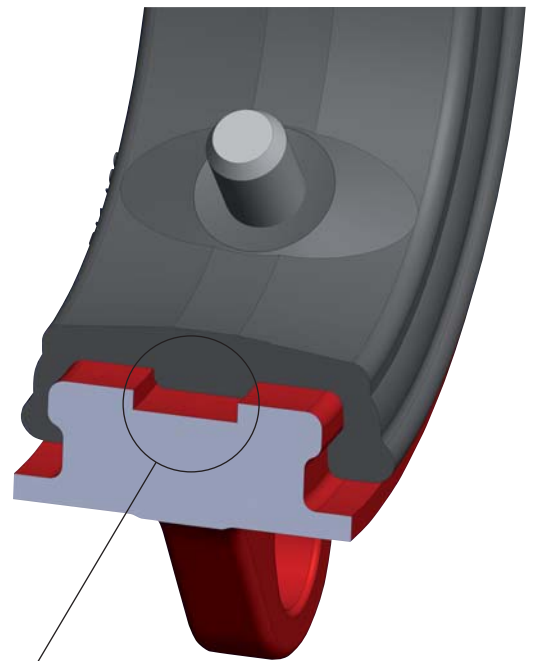

Example of groove and tongue liner anchoring whereby the forming lobe prevents liner movement.



MATERIALS & TECHNICAL INFORMATION

1. EPDM with DVGW CERTIFICATION FOR POTABLE WATER

ABO Series 900 resilient seated butterfly valves are certified by the German Institute DVGW CERT GmbH for potable water applications. Valves with this certification are available in sizes DN32-DN600 and represent a reliable solution for diverse applications for drinking water as well as for the waste water industry.

2. EPDM with FDA APPROVAL FOR FOOD INDUSTRY

ABO series 900 FDA approved black EPDM liner can be used for applications in the food industry from -10C up to 130C. Typical applications for this series are sugar mills, beverage and malt factories.

3. NBR WITH DVGW CERTIFICATION FOR GAS SERVICE

A special NBR seat certified by the German Institute DVGW CERT GmbH is available for gas and biogas applications.

4. VITON BIO LINER FOR BIODIESEL

Viton Bio is a liner with high fluorine content (70%). It provides for excellent chemical resistance and is suitable for such media as acids, oils or biodiesel with temperatures ranging from -5 C to 150C.

5. LINERS FOR EXTREMELY ABRASSIVE MEDIA

Subject to proper material seat selection, ABO series 900 butterfly valves can be used for service in severely abrasive environment:

a) **Carboxylic NBR (Nitrile)** - this basic material variation is suitable for use in an oily environment whereby abrasive particles are present.

b) **Flucast®** - ABO series 900 butterfly valves equipped with Flucast® liners, are the ideal solution for dry bulk conveying, handling of slurries, dust products (gypsum, carbon black, kaolin, oxides), and pneumatic conveying of cement and powder in the mining industry. Depending on the blend, ABO series 900 Flucast® liners can be also used in the food industry (FDA approved), as well as in the oil industry for medias such as crude oil.

WORKING CONDITIONS

- **Max working pressure**
 - o DN 32 - 600: 16 bar
 - o DN 700 - 1600: 10 bar (16 bar upon request)
- **Temperature range - max:**
 - 30°C + 150°C (- 22°F + 302°F), depending on material selection

When temperature of medium increases over + 120 °C, the maximum allowed pressure falls from 16 bar to 14,4 bar, and from 10 bar to 9 bar, respectively.



Series 900 - Biogas application

MATERIALS & TECHNICAL INFORMATION

DRAWING & MATERIALS

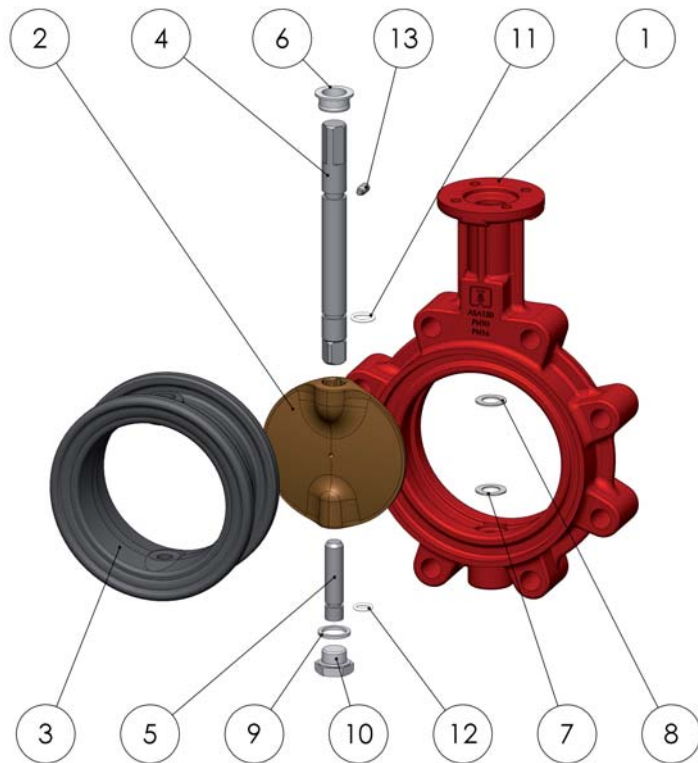

Execution in other material types can be provided upon request. Choice of the seat and disc materials for various media will be recommended upon specific enquiry. Max. temperatures for each material of seat are accepted only for a specific medium and short time exposure.

Item	Name	Material
1	Body	Ductile iron 0.7040 (GGG40) epoxy coated Carbon steel 1.0446 (A216 WCB) Low carbon content steel 1.1156 (A352 LCC) Stainless steel 1.4408 (CF8M) Aluminium EN AC 43000
2	Disc	0 – Brass 2.0402 1 – Aluminium bronze 2.0966 2 – Stainless steel 1.4308 (CF8) 3* – Ductile iron 0.7040 (GGG40), epoxy coated 4* – Stainless steel 1.4408 (CF8M) 5 – HASTELLOY 6 – Stainless steel 1.4539 (Uranus B6) 7 – Titanium
3	Seat	1 - NBR - 10°C + 100°C 2 - EPDM - 25°C + 125°C 3 - Carboxylic NBR - 10°C + 100°C 4 - VITON (FPM) - 15°C + 150°C* 5 - Silicone Steam (MVQ) - 30°C + 140°C 6 - Silicone (VMQ) - 30°C + 150°C 7 - Epichlorohydrin - 30°C + 70°C 8 - HYPALON® (CSM) - 25°C + 120°C 9 - NBR 70-AG - 10°C + 60°C - NBR conduct - 10°C + 80°C
4	Shaft	Stainless steel 1.4021 (AISI 420)
5	Pivot	Stainless steel 1.4021 (AISI 420)
6	Bushing	Delrin (up to DN 300) Brass (from DN 350)
7	Distance ring	Stainless steel
8	Distance ring	Stainless steel
9	Pin	Stainless steel 1.4401 (AISI 316)
10	Retaining screw	Stainless steel
11	Shaft O-ring	NBR, EPDM, VITON is an option
12	Pivot O-ring	NBR, EPDM, VITON is an option

Max. temperature for water services only up to 80 °C.

* Available with optional Rilsan or Halar coating.

INSTALLATION BETWEEN FLANGES (DN 32-600)

Vers.	PN / DN	32/40	50	65	80	100	125	150	200	250	300	350	400	450	500	600	
B	PN 6											•	•	•	•	•	
	PN10																
	PN16													•			
	Class 150											•	•	•	•	•	
T	PN 6	•	•	•	•	•	•	•	•	•	•	•	•	•	X	X	X
	PN10														•	•	•
	PN16									•	•	•	•	•	•	•	•
	Class 150	•	•	•	•	•	•	•	•	•	•	•	•	•	•	•	•

INSTALLATION BETWEEN FLANGES (DN 700 – 1600)

Vers.	PN/DN	700	800	900	1000	1100	1200	1300	1400	1500	1600
F	PN 6	•	•	•	•	•	•	•	•	•	•
	PN 10										
	PN 16	•	•	•	•	•	•	•	•	•	•
	Class 150	•	•	•	•	•	•	•	•	•	•

* For JIS 5K/10K, please consult with ABO.

standard
 upon request
 X not suitable



ACTUATION & TORQUES

ACTUATION POSSIBILITIES

All ABO handles, manual gear operators, pneumatic and electric actuators can be mounted directly to ABO butterfly valves, thus eliminating brackets or couplings. This allows for simple installation in the field, minimizes possible misalignment and decreases overall height.

MANUAL ACTUATION: HANDLEVER

For manual actuation, ABO offers levers in carbon steel material with protective coating for excellent corrosion, abrasion and impact resistance. A lever in stainless steel material is an option. ISO top flange connection is F05 for sizes DN 50 and 65, and F07 for sizes DN 80-200, respectively. Handlever in regulating design optional.

DN 32 - 200

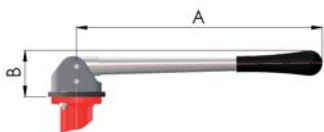

DN 250 - 300

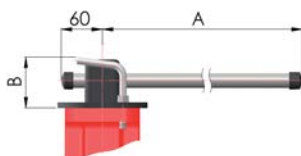

Type L (only up to 6 bar)

DN	32 - 100	125	150 - 200	250	300
A	270	270	362	450	750
B	75	80	90	135	135
Weight	1,24	1,26	1,4	2,2	3,1

Dimensions mentioned in mm, weight in kg.

MANUAL GEARBOX WITH HANDWHEEL

ABO gearbox series of manual actuators combines state of art production technology, with cast iron and pressed steel construction, to provide a smooth and trouble-free operation for heavy duty on-off and throttling service of ABO valves. The rugged, cast iron body seals is weatherproof to IP67. A self-locking gearing holds the valve in the desired position. Further features include a readily accessible hand-wheel, adjustable stopcrew for closed position, removable splined drive bush with indexing facility and a facility to lock handwheel with padlock and chain. Gearboxes, as well as handlevers, can be supplemented with contacts for signalization of endpoints.

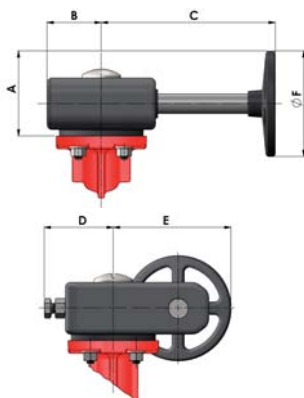

DN	32 - 100	125 - 200	250 - 300	350	400	450-500	600
A	70	78	133,5	133,5	337	348	448
B	35	46	57	57	70	110	110
C	91	110	156	156	350	346	441
D	38	46	60	60	231	196	296
E	84	91	155	155	369	405	505
F	100	100	200	200	600	600	800
Weight	1,2	2,2	4,2	4,3	6,4	28	35
Wheel	CD100	CD100	CD200	SG300	SG600	SG600	SG800

Dimensions mentioned in mm, weight in kg. Valid for Series 242 & AB.

ACTUATORS

- PNEUMATIC ACTUATORS - ABO pneumatic actuators Series 95 are rack and pinion, opposed-piston actuators available in two versions: single acting & double acting
- ELECTRIC ACTUATORS - ABO series 97 electric actuators are designated for quarter turn operating application. Electric actuators of 24V, 230V and 400V can be installed on ABO butterfly valves.

OPERATING TORQUES UPON WORKING PRESSURE (NM)

DN	32/40	50	65	80	100	125	150	200	250	300	350	400	450	500	600
PMA 6 bar	8	11	15	20	38	55	70	100	160	235	480	750	1180	1380	2050
PMA 10 bar	9	12	17	25	46	70	80	125	200	290	530	1200	1550	2050	2700
PMA 16 bar	10	14	20	30	55	85	100	150	220	380	580	1650	2100	2700	3750

DN	700	750	800	900	1000	1100	1200	1300	1400	1500	1600	1800	2000
PMA 10 bar	5800	6630	8090	13740	16320	17350	19320	23660	28000	35000	40600	55860	73150

The above mentioned torques are valid for valves with EPDM seat and stainless steel disk only, and under the condition that the working medium is liquid. While actuating the valve, the above mentioned figures should be multiplied by a coefficient of 1,2. Using a NBR seat, it is necessary to apply a coefficient of 1,4. In case the medium is gaseous, or if it contains abrasive particles, it is necessary to apply a secondary coefficient of 1,35. If the working conditions are specific, it is recommended to discuss the selection of the actuator with the manufacturer.

DIMENSIONS DN 32 - 1600 (1" 1/4 - 64")

DN 32 - 600 (1" 1/4 - 24") PN 6/10/16/Class 150

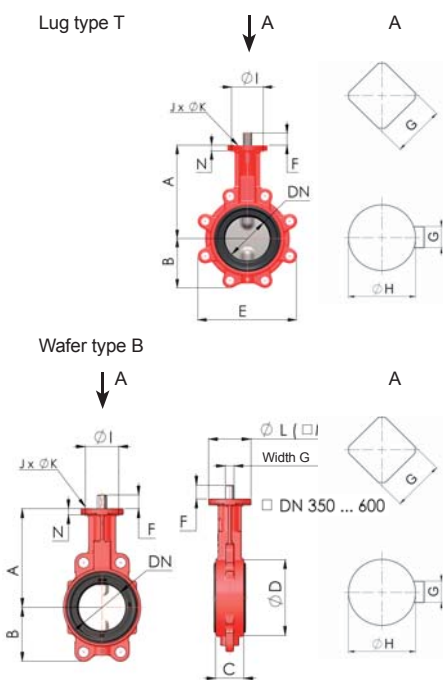

DN	mm		32	40	50	65	80	100	125	150	200	250	300	350	400	450	500	600
	inch		1"1/4	1"1/2	2"	2"1/2	3"	4"	5"	6"	8"	10"	12"	14"	16"	18"	20"	24"
Version	B	A	136	136	146	153,5	163	172,5	192,5	205	234	270	310	325	365	375	482	562
	T	A	136	136	146	153,5	163	172,5	192,5	205	234	270	310	325	365	375	485	565
Valve dimensions	B	54	54	64	72	89	105	118	128	166	202	237	271	314	330	363	464	
	C	33	33	43	46	46	52	56	56	60	68	78	78	102	114	127	154	
	D	78	78	96	113	128	150	184	212	268	320	378	435	488	544	590	695	
	E	110	110	115	129	174	204	234	255	319	396	465	509	590	610	682	810	
	F	25	25	25	25	25	25	25	25	25	30	30	36	36	80	80	80	
Endshaft dimensions	G	14								17		22	22	27	27	10	12	14
	H	-	-	-	-	-	-	-	-	-	-	-	-	-	Ø38	Ø42	Ø50	
ISO TOP Flange	I	50								70		102	102	125	140	140	140	165
	J	4																
	K	7								9		10,5	10,5	14	18	18	18	23
Flange dimensions	L	-	-	70				-	-	-	-	-	-	-	-	175	175	210
	M	70	70	-	-	-	-	75	75	75	105	105	130	140	-	-	-	
	N	8	8	8	8	8	8	9,5	9,5	14	17	17	17	21	22	25	25	
	O	8	8	8	8	8	8	9,5	9,5	14	17	17	17	21	22	25	25	
Weight (kg)	Type B	1,9	1,9	2,7	3,2	3,7	4,7	6,7	8,4	13,3	22,0	29,3	46,4	69,8	83,0	112	216	
	Type T	2,3	2,3	3,0	3,7	4,8	6,1	9,2	10,2	15,3	28,4	41,2	62	96,3	130	149	288	
ISO Flange	F05/F07								F07		F10		F12		F14		F16	

DN 700 - 1600 (28" - 64") PN 10

DN	mm		700	800	900	1000	1200	1400	1600
	inch		28"	32"	36"	40"	48"	56"	64"
Version - F	A	629	666	720	800	940	1009	1150	
Valve dimensions	B	537	601	656	720	844	1014	1045	
	C	165	190	203	216	254	279	318	
	D	840	950	1050	1160	1380	1590	1820	
	E	95	95	130	130	150	150	180	
Endshaft dimensions	F	16	16	20	22	28	32	40	
	G	55	55	75	85	105	120	160	
	H	63	63	84	95	117	134	178	
	M	254	254	254	254	298	356	356	
ISO TOP Flange	I	8	8	8	8	8	8	8	
	J	18	18	18	18	22	33	33	
	K	300	300	300	300	350	415	415	
	L	350	580	700	850	1080	1922	2350	
Weight (kg)		350	580	700	850	1080	1922	2350	
ISO Flange		F25	F25	F25	F25	F30	F35	F35	

For version PN 16 / Class 150 upon request.

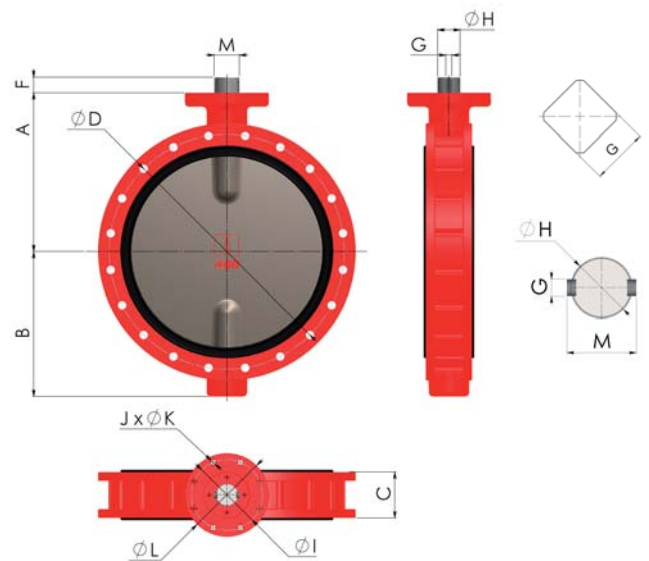

EUROPEAN UNION
European Regional Development Fund
Operational Programme Enterprise
and Innovations for Competitiveness

All statements, technical information in this brochure are tentative and for general use only and do not constitute a recommendation or guarantee for any specific service or application requirement. Consult ABO representative or factory for specific requirements and material selection for your intended application. The right to change or modify product design or product without prior notice is reserved. Binding specification will be provided in each offer. ABO valve accepts no liability for damages caused by bad interpretation or use of the information included in this brochure.

30. 10. 2016

Data subject to change.

United Arab Emirates:
ABO UAE
Abu Dhabi
Tel.: +971 56 9207964
Email: bharti@abovalve.com
www.abovalve.com

Ukraine:
ABO Ukraine LLC
Dnipropetrovsk
Tel.: +38 056 733 95 70
Email: a.marushchak@abovalve.com
www.abovalve.com.ua

Bahrain:
ABO Middle East
Manama
Tel.: +973-3444 9065
Email: jimnichien@abovalve.com
www.abovalve.com

USA:
ABO Controls, LLC
Houston
Email: sales@abovalve.com
www.abovalve.com

Brazil:
ABO do Brasil Válvulas Industriais Eireli
Campinas
Tel.: +55 (19) 3244-6248
Email: m.mansano@abovalve.com
www.abovalve.com

Singapore:
ABO Valve Pte. Ltd.
Singapore
Tel.: +65 9169 4562
Email: lsw@abovalve.com
www.abovalve.com

Turkey:
ABO Armaturen LTD STI
Istanbul
Tel.: +90-216 527 36 34
Email: m.sahin@abovalve.com
www.abovalve.com

China:
ABO Flow Control
Beijing
Tel.: +86 13601522831
Email: wen@abovalve.com
www.abovalve.com

Company HQ - Czech Republic:
ABO valve, s.r.o.
Dalimilova 285/54, 783 35 Olomouc
Tel.: +420 585 224 087
Email: export@abovalve.com
www.abovalve.com

Slovakia:
ABO Slovakia s.r.o.
Banská Bystrica
Tel.: +421 484 145 633
Email: aboslovakia@aboslovakia.sk
www.aboslovakia.sk

Russia:
ABO ARMATURA Ltd.
Smolensk
Tel.: +7 (4812) 240 020
Email: aboarmatura@yandex.ru
www.aboarmatura.ru