



PERFORMANCE RANGE

- Flow rate up to **450 l/min** (27 m³/h)
- Head up to **112 m**

APPLICATION LIMITS

- Manometric suction lift up to **7 m**
- Liquid temperature between **-10 °C** and **+90 °C**
- Ambient temperature between **-10 °C** and **+40 °C**
- Max. working pressure **10 bar**
(**6 bar** for 2CP25/130N)
- Continuous service **S1**

CONSTRUCTION AND SAFETY STANDARDS

EN 60034-1
IEC 60034-1
CEI 2-3



CERTIFICATIONS



AM30



PROMTECT-168

INSTALLATION AND USE

Suitable for use with clean water and liquids that are not chemically aggressive towards the materials from which the pump is made. The high efficiency and adaptability of these pumps to even the most unusual of applications, makes them ideal for use in the domestic, civil and industrial sectors; in particular for the distribution of water in combination with pressure sets, for pressure boosting and in fire-fighting sets.

The pump should be installed in an enclosed environment, or at least sheltered from inclement weather.

OPTIONALS AVAILABLE ON REQUEST

- Special mechanical seal
- Other voltages or 60 Hz frequency
- IPX5 class protection for:
 - 2CP32/200, – 2CP40/180,
 - 2CP32/210, – 2CP40/200

GUARANTEE

2 years subject to terms and conditions

PERFORMANCE RANGE

50 Hz n= 2900 1/min HS= 0 m

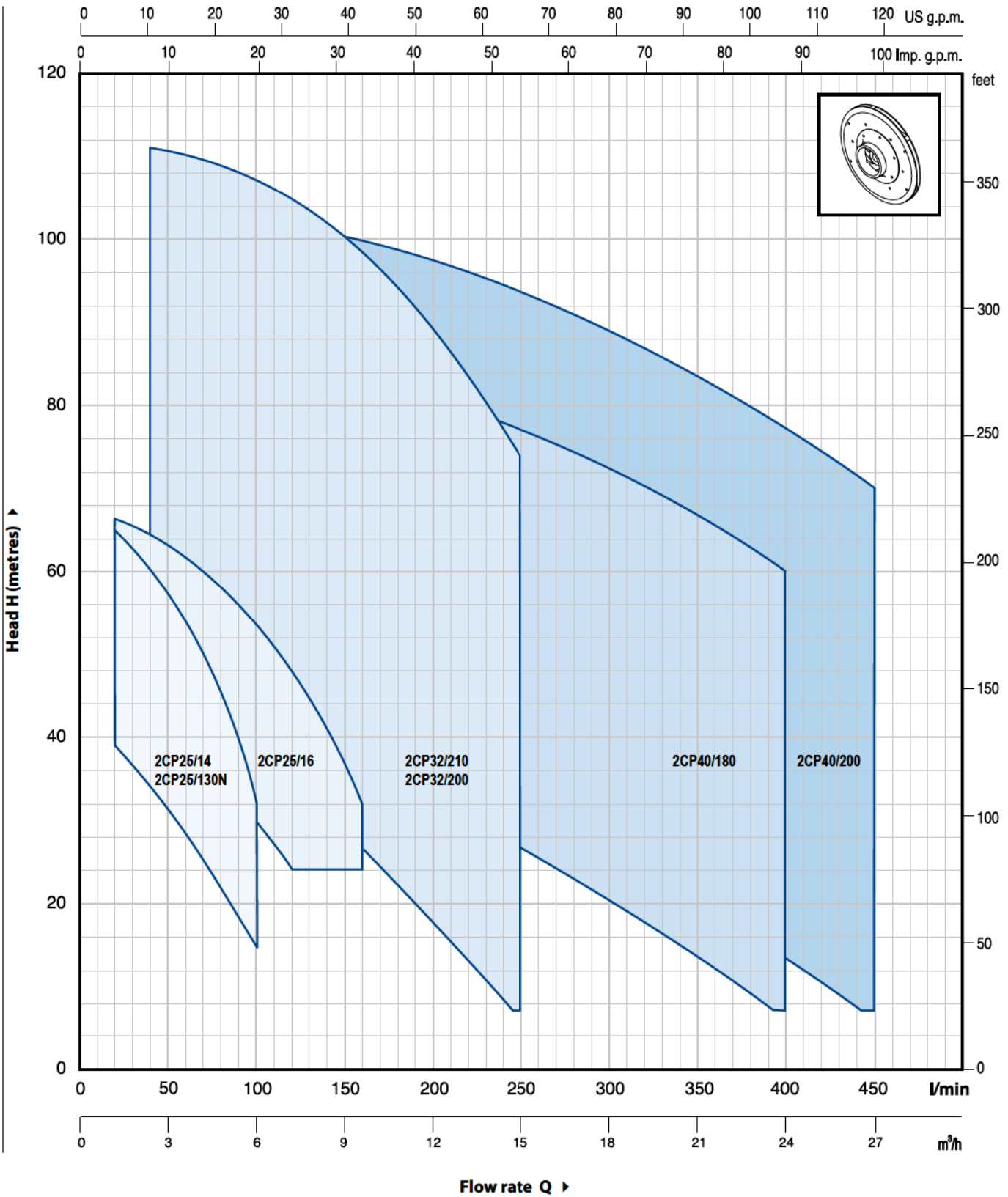

CHARACTERISTIC CURVES AND PERFORMANCE DATA

50 Hz n= 2900 1/min HS= 0 m

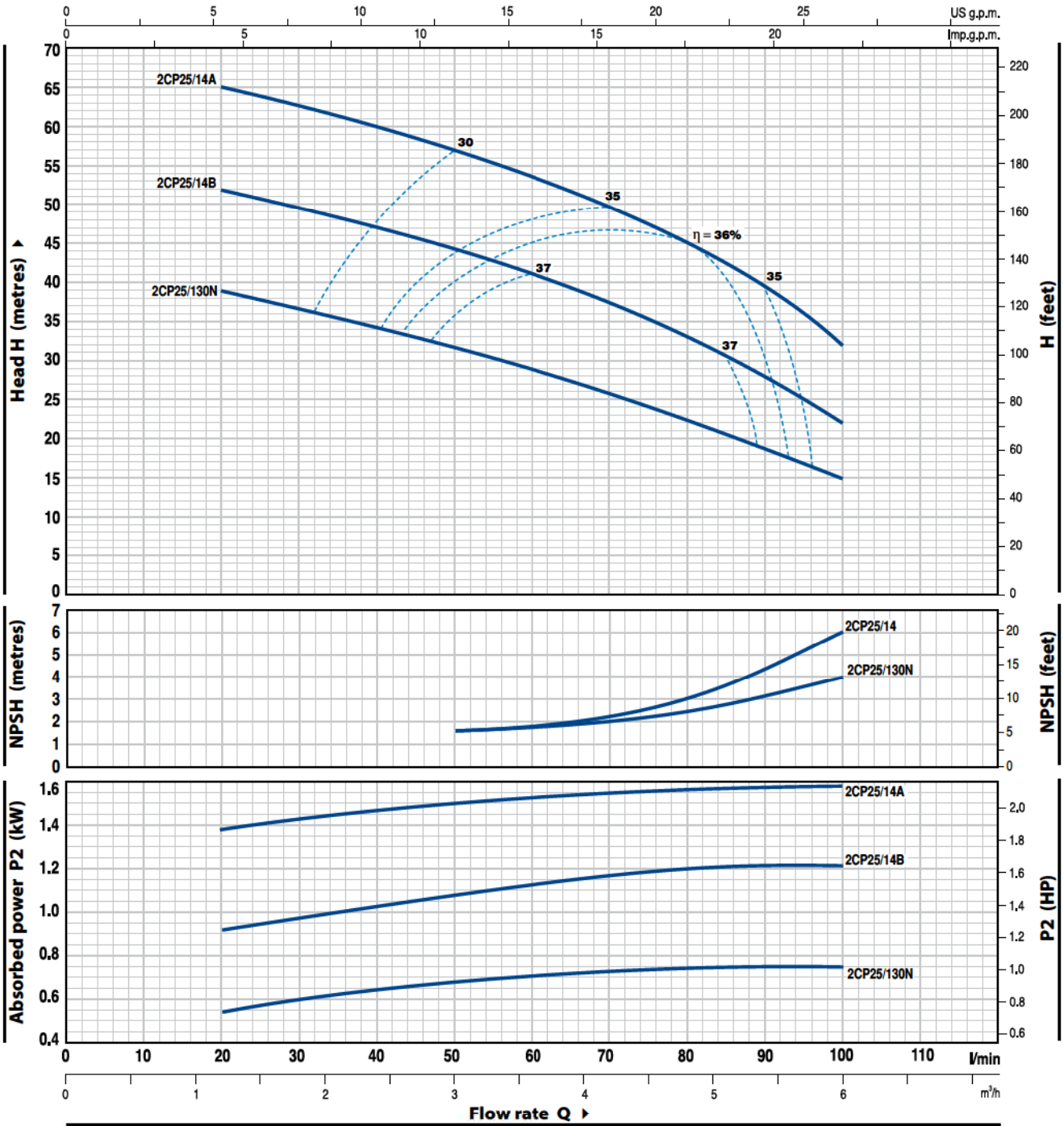

MODEL		POWER		Q	Flow rate											
Single-phase	Three-phase	kW	HP		m³/h	0	1.2	1.8	2.4	3.0	3.6	4.2	4.8	5.4	6.0	
2CPm 25/130N	2CP 25/130N	0.75	1	H metres	0	20	30	40	50	60	70	80	90	100		
2CPm 25/14B	2CP 25/14B	1.1	1.5		42	39	37	34	31	28.5	25.5	22	18	15		
2CPm 25/14A	2CP 25/14A	1.5	2		54	52	50	47.5	44.5	41	37	33	28	22		
					67	65	62	60	57	54	50	45	40	32		

Q = Flow rate H = Total manometric head HS = Suction height

Tolerance of characteristic curves in compliance with EN ISO 9906 Grade 3.

CHARACTERISTIC CURVES AND PERFORMANCE DATA

50 Hz n= 2900 1/min HS= 0 m

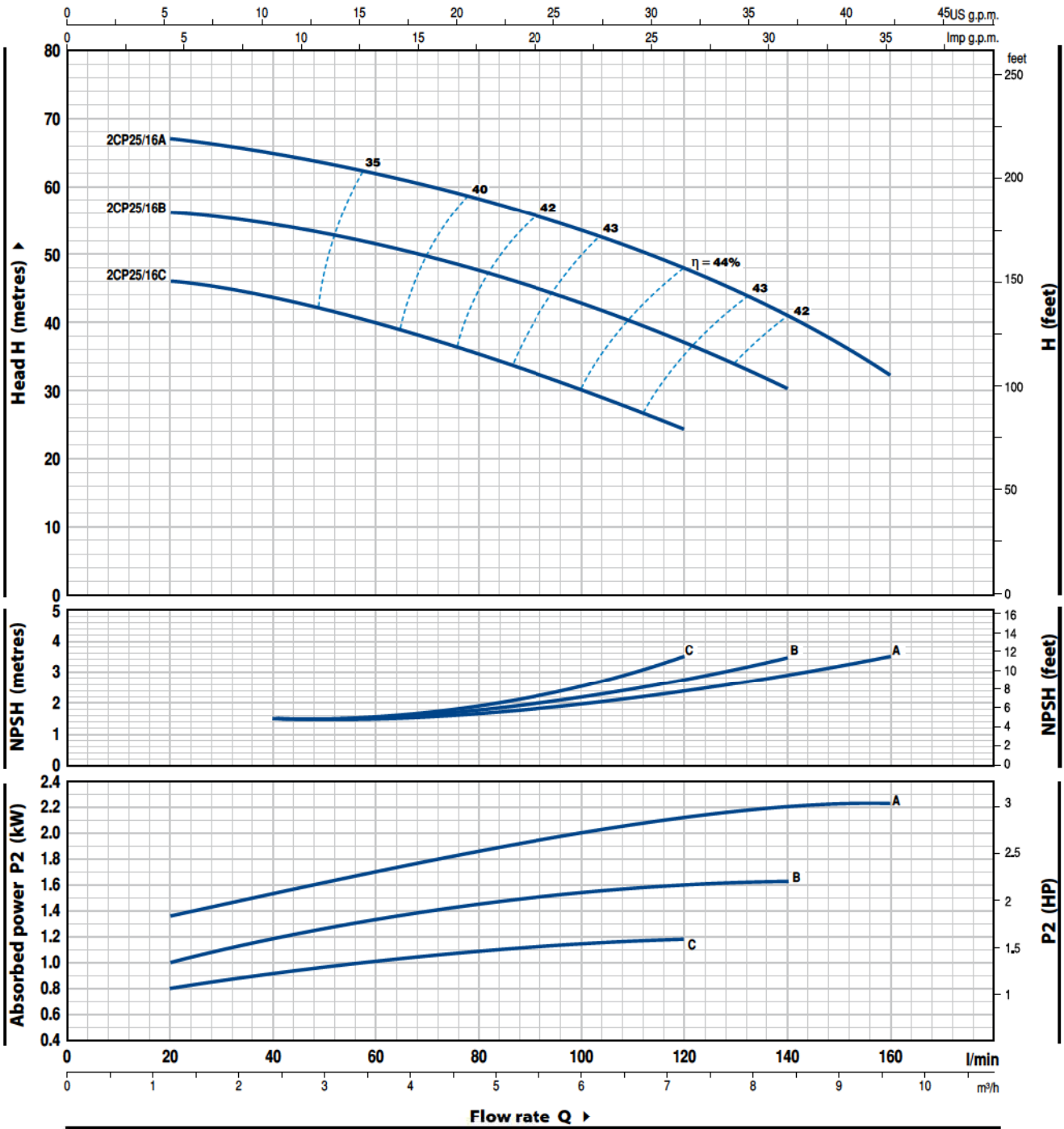

MODEL		POWER		Q	Flow rate															
Single-phase	Three-phase	kW	HP		m³/h	0	1.2	1.8	2.4	3.0	3.6	4.2	4.8	5.4	6.0	6.6	7.2	8.4	9.6	
2CPm 25/16C	2CP 25/16C	1.1	1.5	l/min	0	20	30	40	50	60	70	80	90	100	110	120	140	160		
				H metres	47	46	45	44	42	40	38	35	33	30	27	24				
					58	56	55	54	53	51	49	47	45	43	40	37	30			
					68	67	65.5	64.5	63	62	60	58	56	54	51	48	41	32		

Q = Flow rate H = Total manometric head HS = Suction height

Tolerance of characteristic curves in compliance with EN ISO 9906 Grade 3.

CHARACTERISTIC CURVES AND PERFORMANCE DATA

50 Hz n= 2900 1/min HS= 0 m

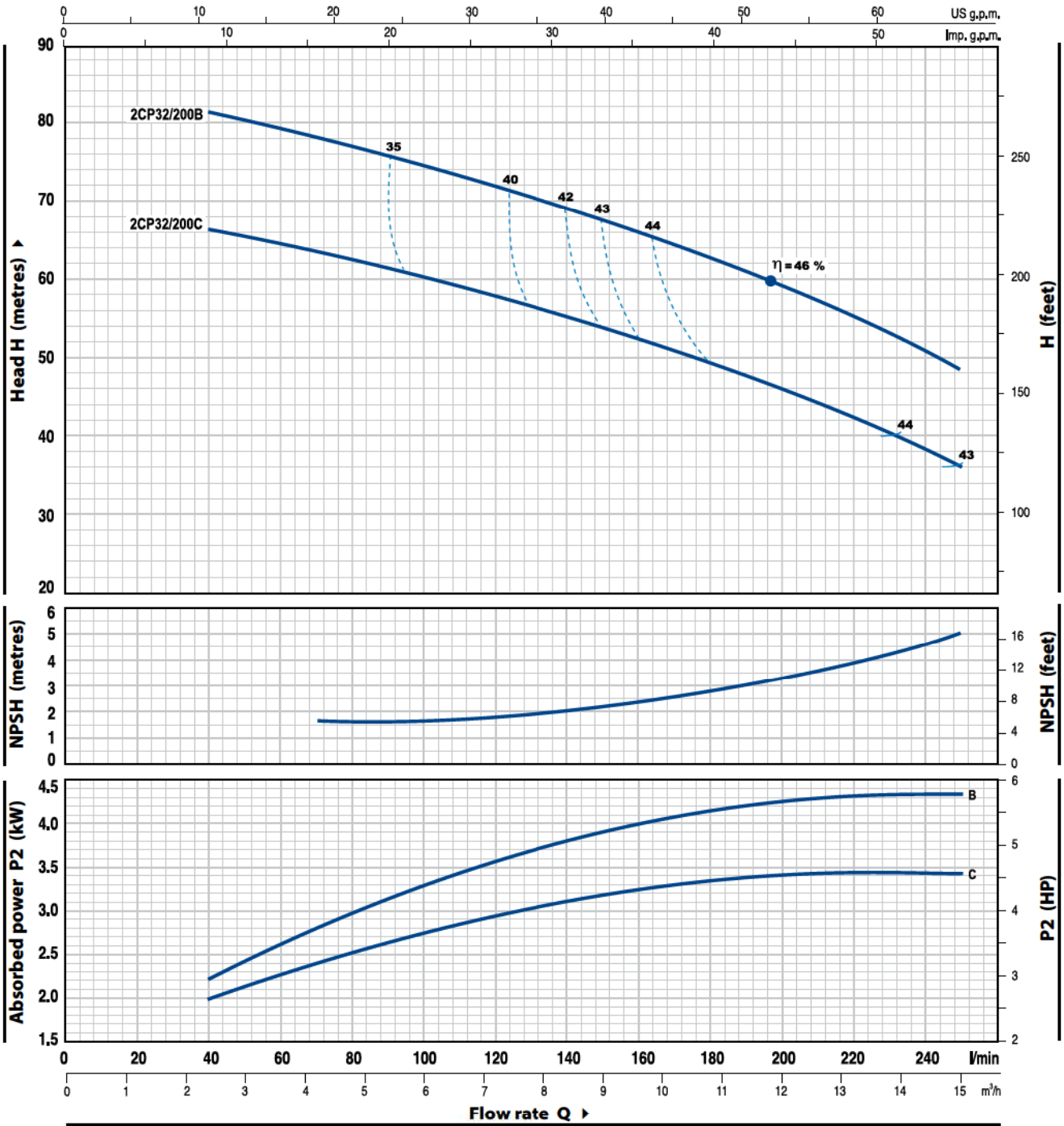

MODEL	POWER		Q	0	2.4	3.0	3.6	4.2	4.8	5.4	6.0	6.6	7.5	8.4	9.6	10.8	12.0	15.0
	kW	HP		0	40	50	60	70	80	90	100	110	125	140	160	180	200	250
Three-phase			l/min	0	40	50	60	70	80	90	100	110	125	140	160	180	200	250
2CP 32/200C	3	4	H metres	70	66.5	65.5	65	64	63	62	60.5	59	57	55	52	49.5	46.5	36
2CP 32/200B	4	5.5		85	81	80	79	78	77	76	75	74	72	69	66	62	58	49

Q = Flow rate H = Total manometric head HS = Suction height

Tolerance of characteristic curves in compliance with EN ISO 9906 Grade 3.

CHARACTERISTIC CURVES AND PERFORMANCE DATA

50 Hz n= 2900 1/min HS= 0 m

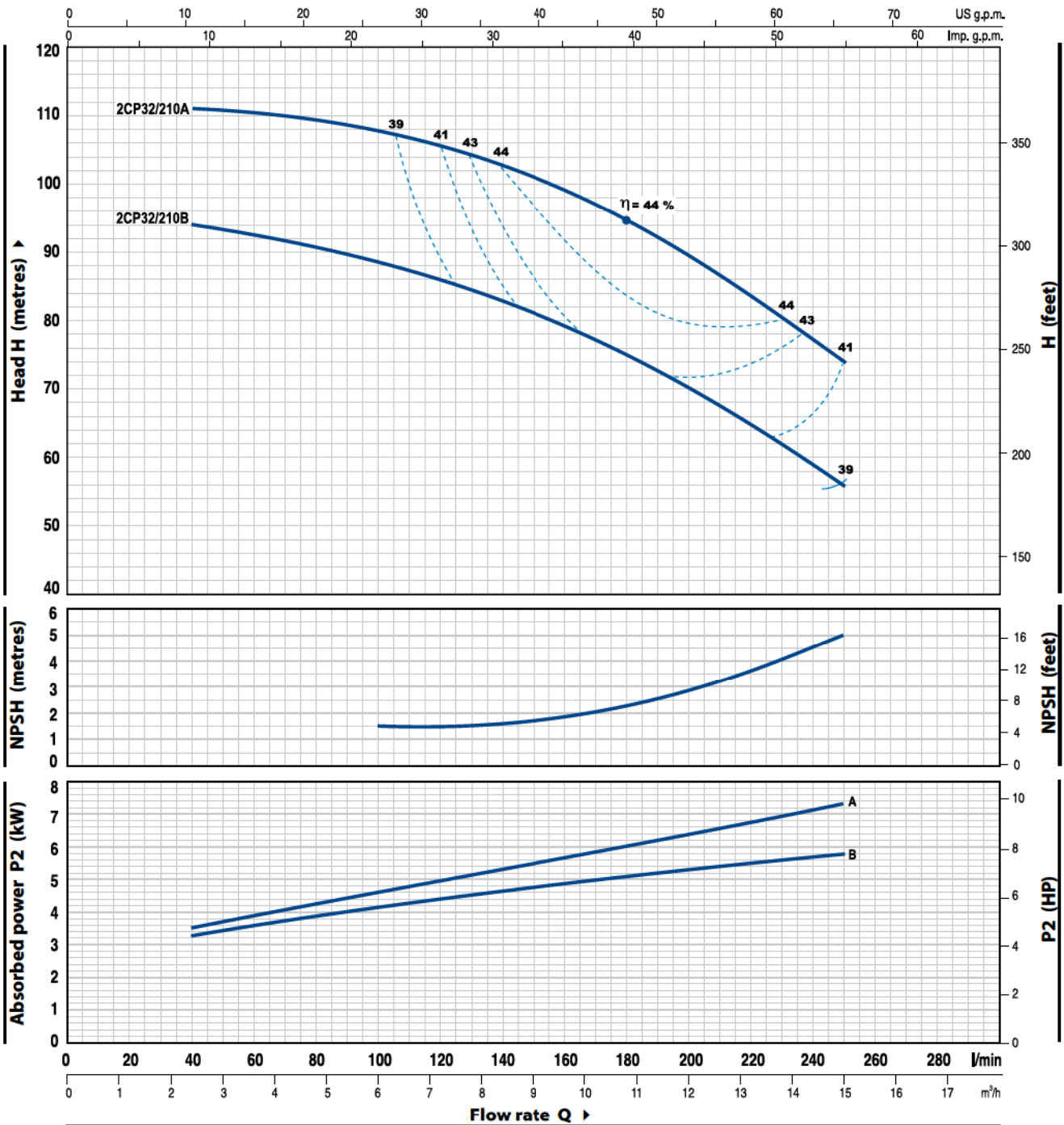

MODEL	POWER		Q	0	2.4	3.0	3.6	4.2	4.8	5.4	6.0	6.6	7.5	8.4	9.6	10.8	12.0	15.0
	kW	HP		0	40	50	60	70	80	90	100	110	125	140	160	180	200	250
Three-phase			H metres	94	94	93.5	93	92	91	90	89	87	85	83	79	75	70	56
2CP 32/210B	5.5	7.5	H metres	112	111	110.8	110.5	110.3	110	109	108	107	105	102	99	94	89	74
2CP 32/210A	7.5	10																

Q = Flow rate H = Total manometric head HS = Suction height

Tolerance of characteristic curves in compliance with EN ISO 9906 Grade 3.

CHARACTERISTIC CURVES AND PERFORMANCE DATA

50 Hz n= 2900 1/min HS= 0 m

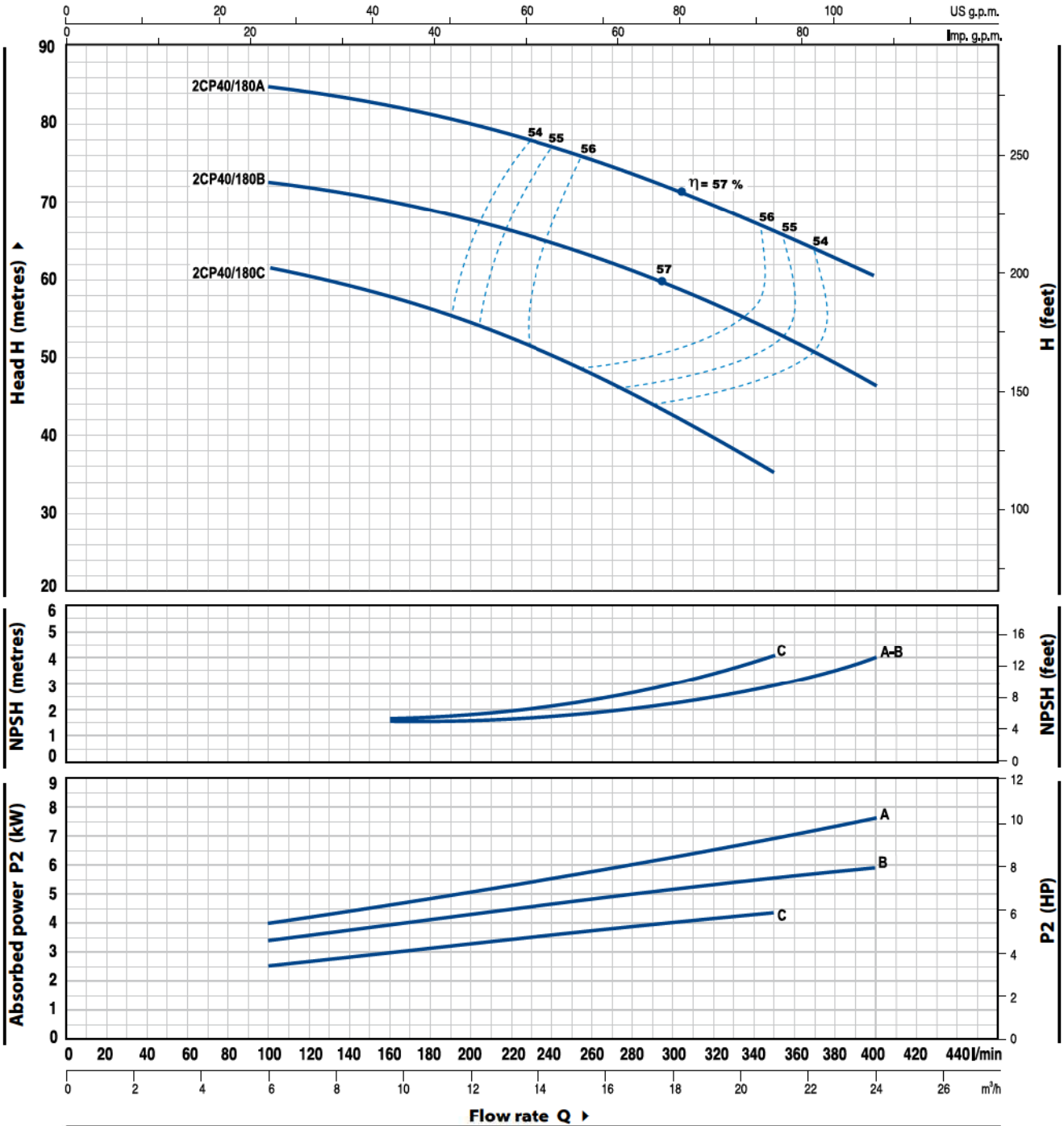

MODEL	POWER		Q	0	6.0	6.6	7.5	8.4	9.6	10.8	12.0	15.0	18.0	21.0	24.0
	kW	HP		0	100	110	125	140	160	180	200	250	300	350	400
Three-phase			H metres	64	62	61	60	59	58	56	54.5	49	43	35	
2CP 40/180C	4	5.5		76	73	72.5	72	71	70	69	67.5	64	59.5	54	46
2CP 40/180B	5.5	7.5		88	85	84.5	84	83	82	81	79.5	76	72	67	60
2CP 40/180A	7.5	10													

Q = Flow rate H = Total manometric head HS = Suction height

Tolerance of characteristic curves in compliance with EN ISO 9906 Grade 3.

CHARACTERISTIC CURVES AND PERFORMANCE DATA

50 Hz n= 2900 1/min HS= 0 m

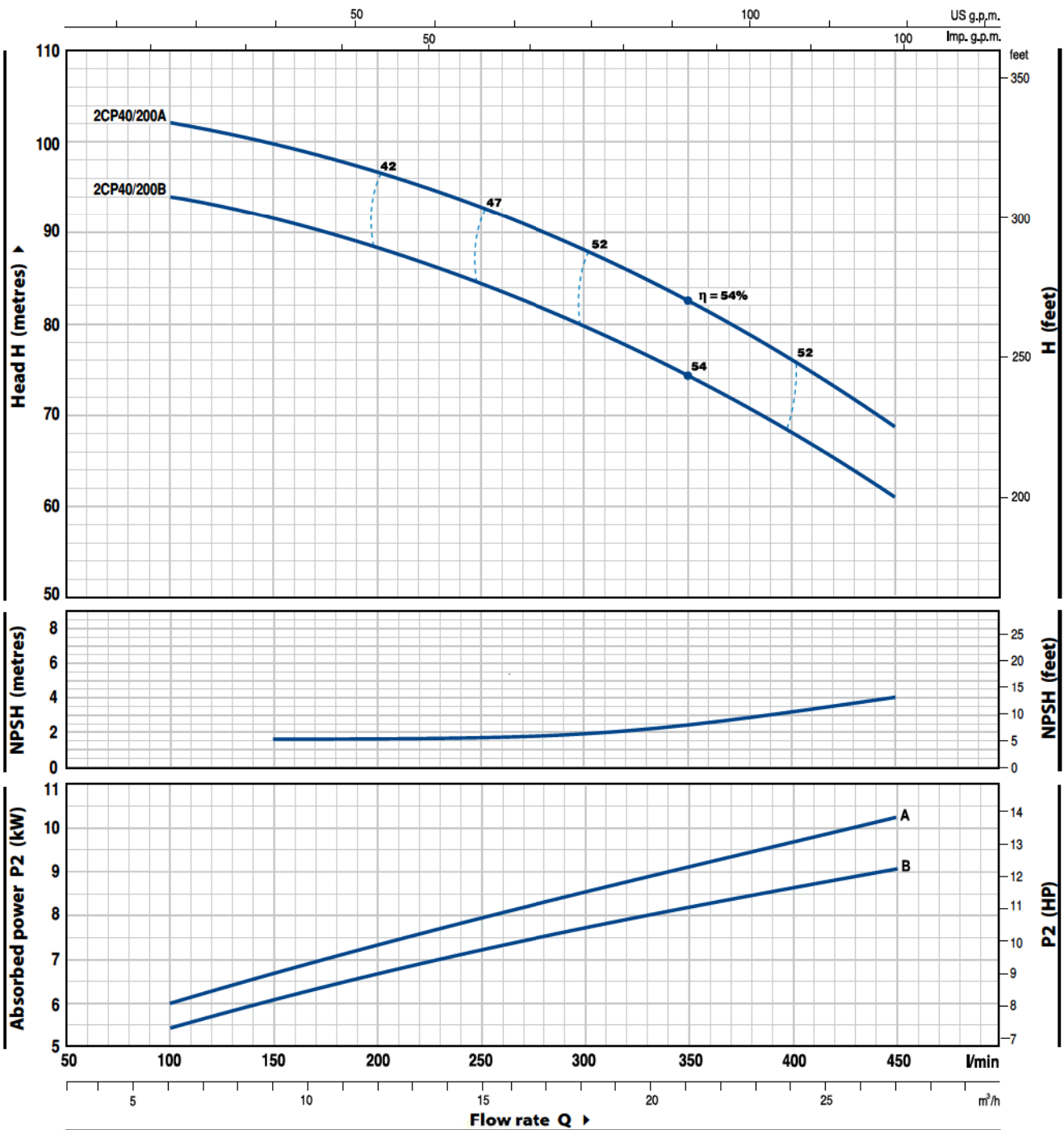

MODEL	POWER		Q	Flow rate												
	kW	HP		m³/h	0	6.0	9	10.8	12.0	15.0	18.0	21.0	24.0	27.0		
Three-phase			l/min	0	100	150	180	200	250	300	350	400	450			
2CP 40/200B	9.2	12.5	H metres	97	94	92	90	88	85	80	74	68	61			
2CP 40/200A	11	15		105	102	100	98	97	93	88	83	76	69			

Q = Flow rate H = Total manometric head HS = Suction height

Tolerance of characteristic curves in compliance with EN ISO 9906 Grade 3.

2CP 25/130N

POS.	COMPONENT	CONSTRUCTION CHARACTERISTICS				
1	PUMP BODY	Cast iron, complete with threaded ports in compliance with ISO 228/1				
2	BODY BACKPLATE	Stainless steel AISI 304				
3	IMPELLERS	Stainless steel AISI 304				
4	MOTOR SHAFT	Stainless steel EN 10088-3 - 1.4104				
5	MECHANICAL SEAL	<i>Seal</i>	<i>Shaft</i>	<i>Materials</i>		
		<i>Model</i>	<i>Diameter</i>	<i>Stationary ring</i>	<i>Rotational ring</i>	<i>Elastomer</i>
		AR-14	Ø 14 mm	Ceramic	Graphite	NBR
6	BEARINGS	6203 ZZ / 6203 ZZ				
7	CAPACITOR	<i>Pump</i>	<i>Capacitance</i>			
		<i>Single-phase</i>	<i>(230 V or 240 V)</i>		<i>(110 V)</i>	
		2CPm 25/130N	20 µF 450 VL		60 µF 300 VL	
8	ELECTRIC MOTOR	<p>2CPm 25/130N: single-phase 230 V - 50 Hz with thermal overload protector built-in to the winding.</p> <p>2CP 25/130N: three-phase 230/400 V - 50 Hz.</p> <p>⇒ Pump fitted with the three-phase motor option offers IE2 (IEC 60034-30) class high performance</p> <ul style="list-style-type: none"> - Insulation: F class. - Protection: IP X4. 				

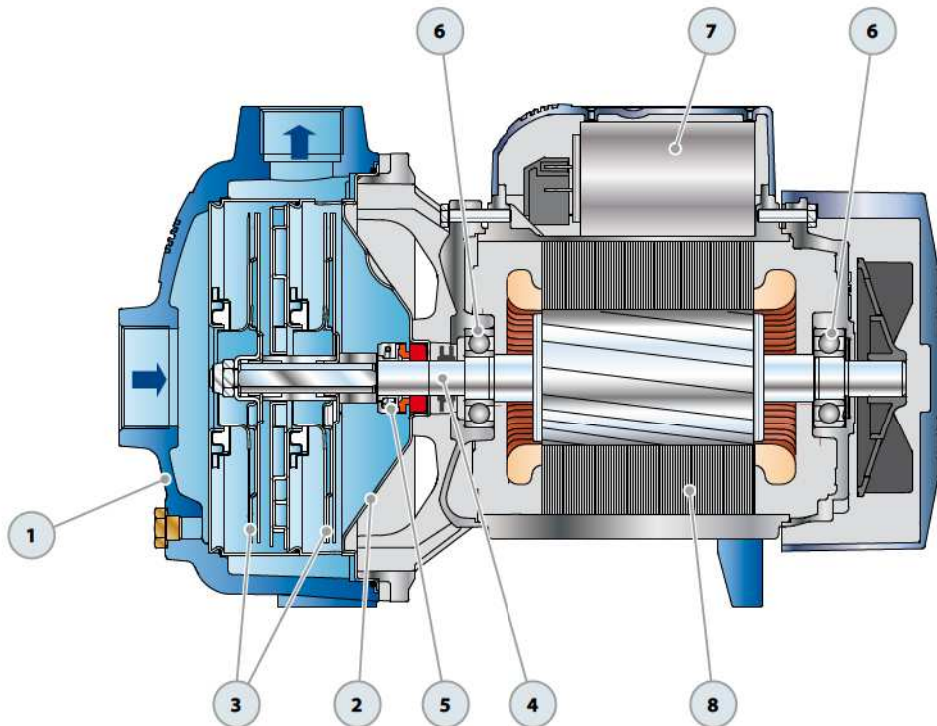

DIMENSIONS AND WEIGHT

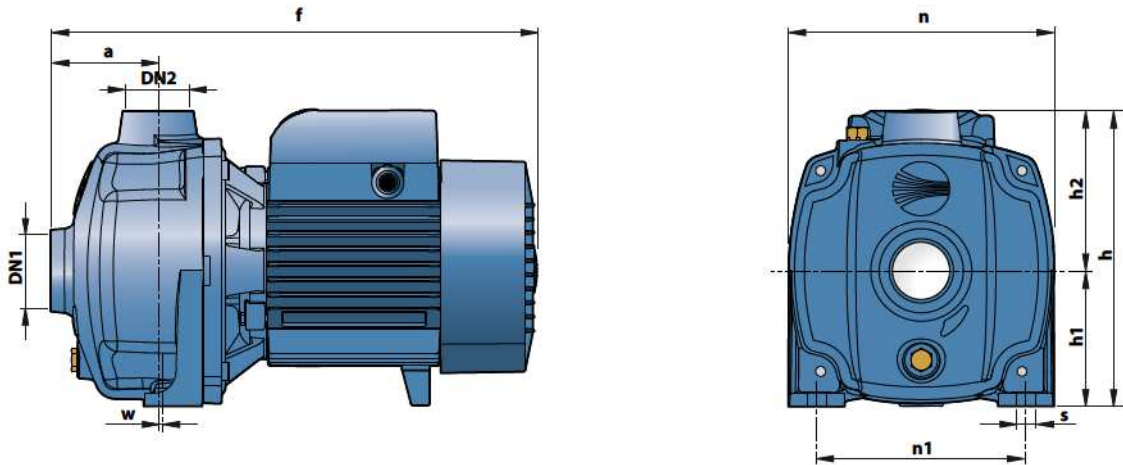

MODEL		PORTS		DIMENSIONS mm									kg	
Single-phase	Three-phase	DN1	DN2	a	f	h	h1	h2	n	n1	w	s	1~	3~
2CPm 25/130N	2CP 25/130N	1 1/4"	1"	73	330	201	92	109	180	142	1	10	14.5	14.0

ABSORPTION

MODEL	VOLTAGE (single-phase)		
	Single-phase	230 V	240 V
2CPm 25/130N	6.3 A	6.0 A	12.6 A

MODEL	VOLTAGE (three-phase)					
	Three-phase	230 V	400 V	690 V	240 V	415 V
2CP 25/130N	4.6 A	2.6 A	1.5 A	4.3 A	2.5 A	1.5 A

PALLETIZATION

MODEL		GROUPAGE				CONTAINER			
Single-phase	Three-phase	n° pumps	H (mm)	kg		n° pumps	H (mm)	kg	
				1~	3~			1~	3~
2CPm 25/130N	2CP 25/130N	60	1320	890	860	84	1790	1240	1200

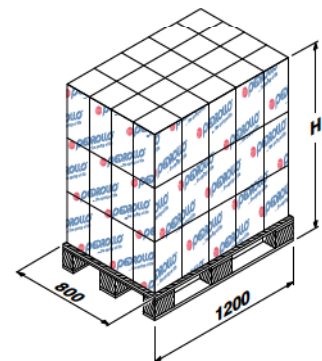

POS.	COMPONENT	CONSTRUCTION CHARACTERISTICS					
1	PUMP BODY	Cast iron, complete with threaded ports in compliance with ISO 228/1					
2	IMPELLERS	Brass					
3	MOTOR SHAFT	Stainless steel EN 10088-3 - 1.4104					
4	MECHANICAL SEAL	<i>Pump</i>	<i>Seal</i>	<i>Shaft</i>	<i>Materials</i>		
		<i>Model</i>	<i>Model</i>	<i>Diameter</i>	<i>Stationary ring</i>	<i>Rotational ring</i>	<i>Elastomer</i>
		2CP 25/14	FN-18	Ø 18 mm	Graphite	Ceramic	NBR
		2CP 25/16					
		2CP 32/200	FN-20	Ø 20 mm	Graphite	Ceramic	NBR
		2CP 32/210					
		2CP 40/180	FN-24	Ø 24 mm	Graphite	Ceramic	NBR
2CP 40/200	FN-32 NU	Ø 32 mm	Graphite	Ceramic	NBR		
5	BEARINGS	<i>Pump</i>	<i>Model</i>				
		2CP 25/14	6204 ZZ / 6204 ZZ				
		2CP 25/16					
		2CP 32/200	6206 ZZ - C3 / 6206 ZZ - C3				
		2CP 32/210					
		2CP 40/180	6306 ZZ - C3 / 6206 ZZ - C3				
		2CP 40/200	6308 ZZ - C3 / 6308 ZZ - C3				
6	CAPACITOR	<i>Pump</i>	<i>Capacitance</i>				
		<i>Single-phase</i>	<i>(230 V or 240 V)</i>	<i>(110 V)</i>			
		2CPm 25/14B	25 µF 450 VL	60 µF 250 VL			
		2CPm 25/16C					
		2CPm 25/14A	45 µF 450 VL	80 µF 250 VL			
7	ELECTRIC MOTOR	2CPm: single-phase 230 V - 50 Hz with thermal overload protector built-in to the winding.					
		2CP: three-phase 230/400 V - 50 Hz up to 4 kW. 400/690 V - 50 Hz from 5.5 to 11 kW					
<p>⇒ Pumps fitted with the three-phase motor option offer IE2 (IEC 60034-30) class high performance</p> <ul style="list-style-type: none"> - Insulation: F class. - Protection: IPX4. 							

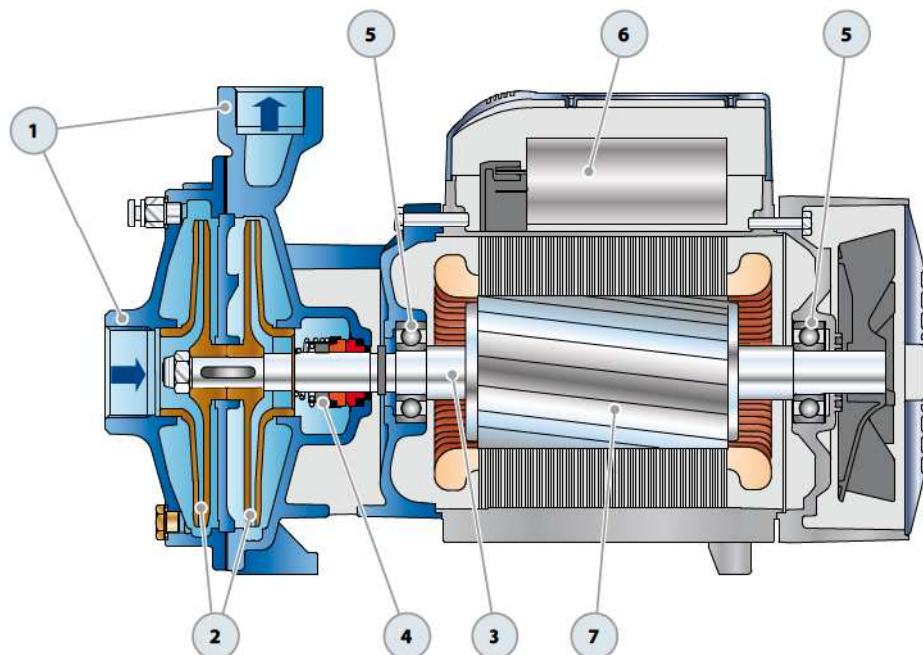

DIMENSIONS AND WEIGHT

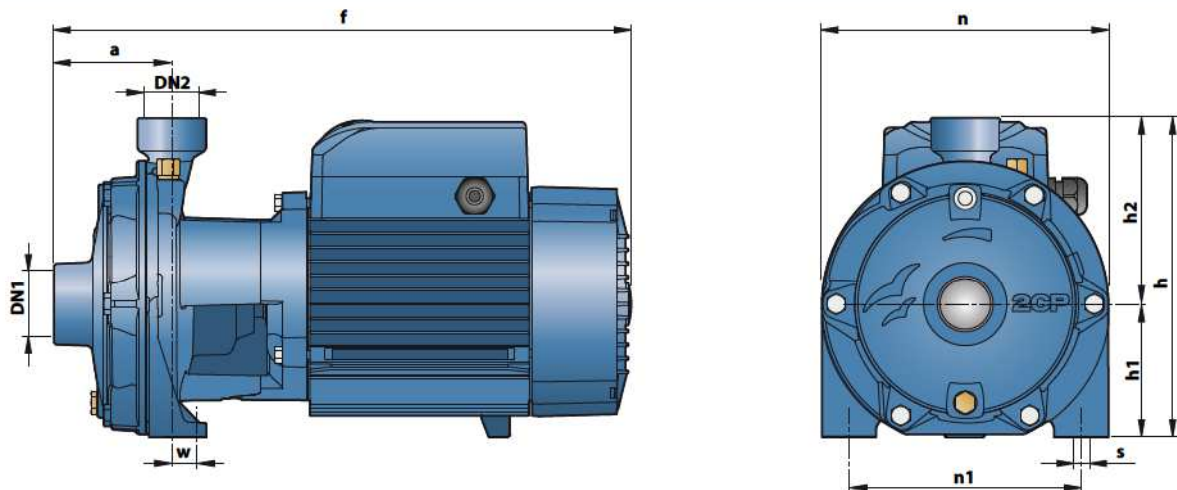

MODEL		PORTS		DIMENSIONS mm									kg		
Single-phase	Three-phase	DN1	DN2	a	f	h	h1	h2	n	n1	w	s	1~	3~	
2CPm 25/14B	2CP 25/14B	1 1/4"	1"	82	404	223	93	130	200	162	17	10	19.4	18.8	
2CPm 25/14A	2CP 25/14A					261	110	151	225	185	26	11	24.2	23.0	
2CPm 25/16C	2CP 25/16C					223	93	130	200	162	17	10	19.4	18.8	
2CPm 25/16B	2CP 25/16B					261	110	151	225	185	26	11	24.3	23.2	
-	2CP 25/16A												-	24.5	
-	2CP 32/200C-B	1 1/2"	1 1/4"	95	464	304	132	172	266	206	19		-	38.0/43.0	
-	2CP 32/210B-A					542	334	139	195	292	232	21	14	-	54.0/61.0
-	2CP 40/180C	2"	1 1/2"	108	496	542	334	139	195	292	232	21	14	-	49.0
-	2CP 40/180B-A					542	334	139	195	292	232	21	14	-	54.0/60.0
-	2CP 40/200B-A					110	566	355	160	195	298				

ABSORPTION

MODEL	VOLTAGE (single-phase)		
	230 V	240 V	110 V
Single-phase	230 V	240 V	110 V
2CPm 25/14B	7.7 A	7.4 A	15.5 A
2CPm 25/14A	10.5 A	10.0 A	21.0 A
2CPm 25/16C	7.7 A	7.4 A	15.5 A
2CPm 25/16B	10.0 A	9.6 A	20.0 A

MODEL	VOLTAGE (three-phase)					
	230 V	400 V	690 V	240 V	415 V	720 V
Three-phase	230 V	400 V	690 V	240 V	415 V	720 V
2CP 25/14B	5.4 A	3.1 A	1.8 A	5.2 A	3.0 A	1.7 A
2CP 25/14A	6.9 A	4.0 A	2.3 A	6.6 A	3.8 A	2.2 A
2CP 25/16C	5.4 A	3.1 A	1.8 A	5.2 A	3.0 A	1.7 A
2CP 25/16B	6.9 A	4.0 A	2.3 A	6.6 A	3.8 A	2.2 A
2CP 25/16A	9.2 A	5.3 A	3.1 A	8.8 A	5.1 A	2.9 A
2CP 32/200C	12.8 A	7.4 A	4.3 A	12.3 A	7.1 A	4.1 A
2CP 32/200B	18.2 A	10.5 A	6.1 A	17.7 A	10.2 A	5.9 A
2CP 32/210B	21.7 A	12.5 A	7.2 A	19.9 A	11.5 A	6.7 A
2CP 32/210A	27.7 A	16.0 A	9.2 A	26.0 A	15.0 A	8.7 A
2CP 40/180C	17.0 A	9.8 A	5.7 A	16.5 A	9.5 A	5.5 A
2CP 40/180B	21.3 A	12.3 A	7.1 A	20.8 A	12.0 A	6.9 A
2CP 40/180A	26.7 A	15.4 A	8.9 A	26.0 A	15.0 A	8.7 A
2CP 40/200B	-	17.5 A	10.1 A	-	17.5 A	10.1 A
2CP 40/200A	-	20.0 A	11.5 A	-	20.0 A	11.5 A

PALLETIZATION

MODEL		GROUPAGE			CONTAINER				
Single-phase	Three-phase	n° pumps	H (mm)	kg		n° pumps	H (mm)	kg	
				1~	3~			1~	3~
2CPm 25/14B	2CP 25/14B	50	1415	994	964	70	1925	1382	1340
2CPm 25/14A	2CP 25/14A	50	1590	1234	1174	70	2170	1718	1634
2CPm 25/16C	2CP 25/16C	50	1415	994	964	70	1925	1382	1340
2CPm 25/16B	2CP 25/16B	50	1590	1239	1184	70	2170	1725	1648
-	2CP 25/16A	50	1590	-	1249	70	2170	-	1739
-	2CP 32/200C	18	1420	-	700	24	1840	-	930
-	2CP 32/200B	18	1420	-	790	24	1840	-	1050
-	2CP 32/210B	12	1420	-	670	16	1840	-	880
-	2CP 32/210A	12	1420	-	750	16	1840	-	1000
-	2CP 40/180C	12	1420	-	610	16	1840	-	800
-	2CP 40/180B	12	1420	-	670	16	1840	-	880
-	2CP 40/180A	12	1420	-	740	16	1840	-	980
-	2CP 40/200B	6	1200	-	551	9	1730	-	818
-	2CP 40/200A	6	1200	-	557	9	1730	-	827

