



PERFORMANCE RANGE

- Flow rate up to **450 l/min** (27 m³/h)
- Head up to **112 m**

APPLICATION LIMITS

- Manometric suction lift up to **7 m**
- Liquid temperature between **-10 °C** and **+90 °C**
(up to +40 for the version with the technopolymer impeller)
- Ambient temperature between **-10 °C** and **+40 °C**
- Max. working pressure **10 bar**
(**6 bar** for 2CP25/130N)
- Continuous service **S1**

CONSTRUCTION AND SAFETY STANDARDS

EN 60034-1
IEC 60034-1
CEI 2-3



CERTIFICATIONS



INSTALLATION AND USE

Suitable for use with clean water and liquids that are not chemically aggressive towards the materials from which the pump is made. The high efficiency and adaptability of these pumps to even the most unusual of applications, makes them ideal for use in the domestic, civil and industrial sectors; in particular for the distribution of water in combination with pressure sets, for pressure boosting and in fire-fighting sets.

The pump should be installed in an enclosed environment, or at least sheltered from inclement weather.

OPTIONALS AVAILABLE ON REQUEST

- Pumps with technopolymer impeller
- Special mechanical seal
- Other voltages or 60 Hz frequency
- IP55 class protection for:
 - 2CP32/200, – 2CP40/180,
 - 2CP32/210, – 2CP40/200

GUARANTEE

2 years subject to terms and conditions

CHARACTERISTIC CURVES AND PERFORMANCE DATA

50 Hz n= 2900 1/min HS= 0 m

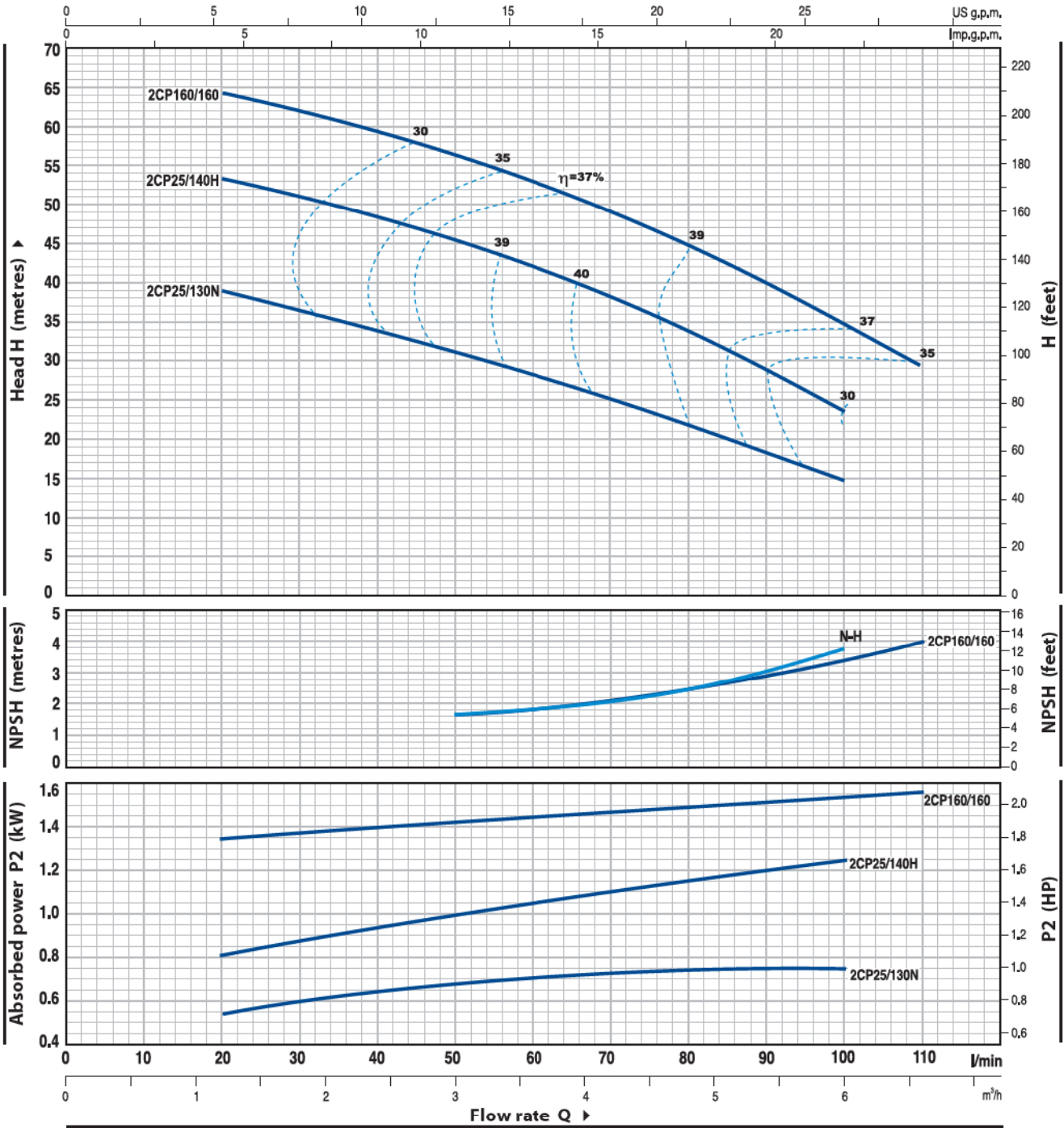

MODEL		POWER		Q	Flow rate													
Single-phase	Three-phase	kW	HP		m³/h	0	1.2	1.8	2.4	3.0	3.6	4.2	4.8	5.4	6.0	6.6		
2CPm 25/130N	2CP 25/130N	0.75	1	l/min	0	20	30	40	50	60	70	80	90	100	110			
				H metres	42	39	37	34	31	28.5	25.5	22	18	15				
					54	53	51	49	46	42	38	34	29	24				
					66	64	62	60	57	53	49	44	39.5	35	30			

Q = Flow rate H = Total manometric head HS = Suction height

Tolerance of characteristic curves in compliance with EN ISO 9906 App. A.

POS.	COMPONENT	CONSTRUCTION CHARACTERISTICS					
1	PUMP BODY	Cast iron, complete with threaded ports in compliance with ISO 228/1					
2	IMPELLERS	Brass					
3	MOTOR SHAFT	Stainless steel EN 10088-3 - 1.4104					
4	MECHANICAL SEAL	<i>Pump</i>	<i>Seal</i>	<i>Shaft</i>	<i>Materials</i>		
		<i>Model</i>	<i>Model</i>	<i>Diameter</i>	<i>Stationary ring</i>	<i>Rotational ring</i>	<i>Elastomer</i>
		2CP 25/140					
		2CP 25/160	FN-18	Ø 18 mm	Graphite	Ceramic	NBR
		2CP 160/160					
		2CP 32/200	FN-20	Ø 20 mm	Graphite	Ceramic	NBR
		2CP 32/210	FN-24	Ø 24 mm	Graphite	Ceramic	NBR
2CP 40/180							
2CP 40/200	FN-32 NU	Ø 32 mm	Graphite	Ceramic	NBR		
5	BEARINGS	<i>Pump</i>	<i>Model</i>				
		2CP 25/140					
		2CP 25/160	6204 ZZ / 6204 ZZ				
		2CP 160/160					
		2CP 32/200	6206 ZZ - C3 / 6206 ZZ - C3				
		2CP 32/210	6306 ZZ - C3 / 6206 ZZ - C3				
		2CP 40/180					
2CP 40/200	6308 ZZ - C3 / 6308 ZZ - C3						
6	CAPACITOR	<i>Pump</i>	<i>Capacitance</i>				
		<i>Single-phase</i>	<i>(230 V or 240 V)</i>	<i>(110 V)</i>			
		2CPm 25/140	25 µF 450 VL	60 µF 250 VL			
		2CPm 160/160	45 µF 450 VL	80 µF 250 VL			
2CPm 25/160B	45 µF 450 VL	80 µF 250 VL					
7	ELECTRIC MOTOR	2CPm: single-phase 230 V - 50 Hz with thermal overload protector built-in to the winding.					
		2CP: three-phase 230/400 V - 50 Hz up to 4 kW. 400/690 V - 50 Hz from 5.5 to 11 kW					
<p>⇒ Pumps fitted with the three-phase motor option offer IE2 (IEC 60034-30) class high performance</p> <ul style="list-style-type: none"> - Insulation: F class. - Protection: IP 44. 							

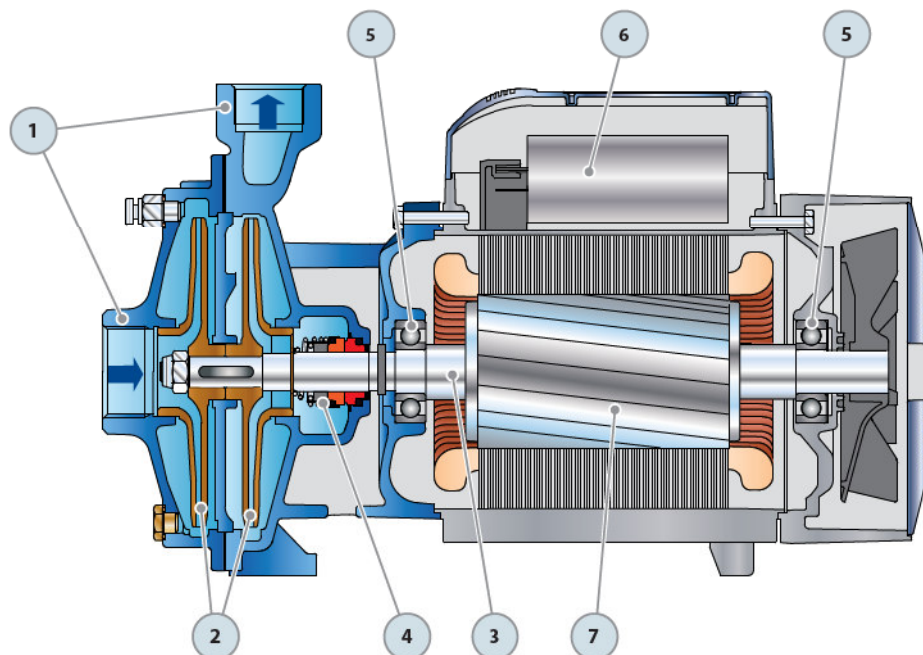

DIMENSIONS AND WEIGHT

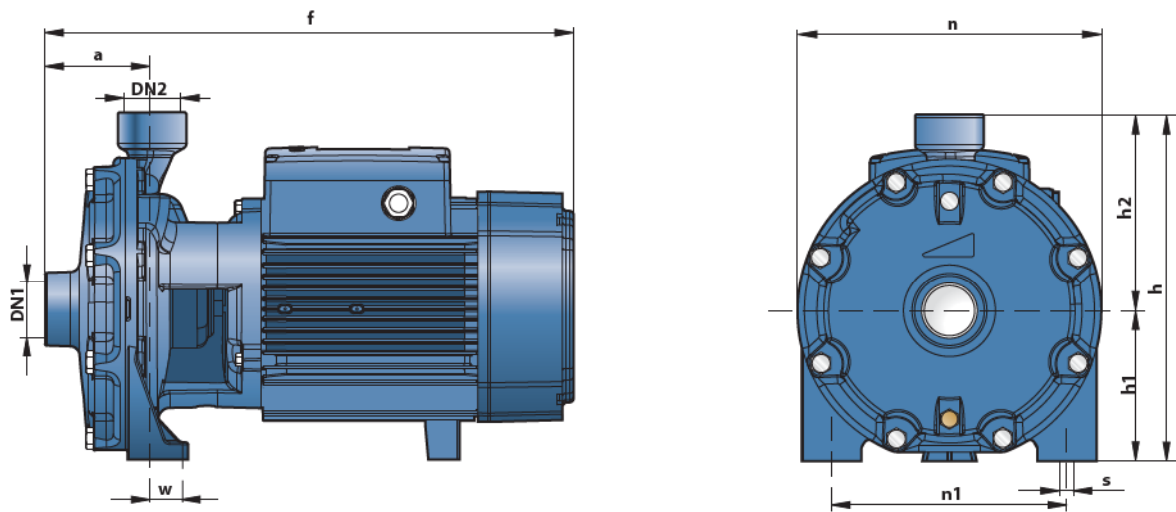

MODEL		PORTS		DIMENSIONS mm									kg	
Single-phase	Three-phase	DN1	DN2	a	f	h	h1	h2	n	n1	w	s	1~	3~
2CPm 25/140H	2CP 25/140H	1 1/4"	1"	74	382	225	93	132	200	162	23	10	18.9	18.3
2CPm 160/160	2CP 160/160			84	405	263	110	153	225	185	26	11	24.5	23.3
2CPm 25/140M	2CP 25/140M			74	382	225	93	132	200	162	23	10	18.9	18.3
2CPm 25/160B	2CP 25/160B-A	1 1/2"	1 1/4"	86	407	263	110	153	225	185	26	11	24.3	23.2/ 24.5
-	2CP 32/200C-B			95	464	304	132	172	266	206	19	-	38.0/43.0	
-	2CP 32/210B-A	2"	1 1/2"		542								-	54.0/61.0
-	2CP 40/180C			108	496	334	139	195	292	232	21	14	-	49.0
-	2CP 40/180B-A				542									-
-	2CP 40/200B-A			110	566	355	160	195	298				-	89.0/90.0

ABSORPTION

MODEL	VOLTAGE (single-phase)		
	230 V	240 V	110 V
Single-phase			
2CPm 25/140H	7.6 A	7.0 A	15.2 A
2CPm 160/160	11.0 A	10.0 A	21.0 A
2CPm 25/140M	8.0 A	7.3 A	16.0 A
2CPm 25/160B	11.0 A	10.0 A	21.0 A

MODEL	VOLTAGE (three-phase)					
	230 V	400 V	690 V	240 V	415 V	720 V
Three-phase						
2CP 25/140H	5.7 A	3.3 A	1.9 A	5.2 A	3.0 A	1.7 A
2CP 160/160	8.0 A	4.6 A	2.7 A	7.0 A	4.0 A	2.3 A
2CP 25/140M	5.9 A	3.4 A	2.0 A	5.4 A	3.1 A	1.8 A
2CP 25/160B	8.0 A	4.6 A	2.7 A	7.7 A	4.4 A	2.6 A
2CP 25/160A	9.3 A	5.4 A	3.1 A	8.7 A	5.0 A	2.9 A
2CP 32/200C	12.8 A	7.4 A	4.3 A	12.3 A	7.1 A	4.1 A
2CP 32/200B	18.2 A	10.5 A	6.1 A	17.7 A	10.2 A	5.9 A
2CP 32/210B	21.7 A	12.5 A	7.2 A	19.9 A	11.5 A	6.7 A
2CP 32/210A	27.7 A	16.0 A	9.2 A	26.0 A	15.0 A	8.7 A
2CP 40/180C	17.0 A	9.8 A	5.7 A	16.5 A	9.5 A	5.5 A
2CP 40/180B	21.3 A	12.3 A	7.1 A	20.8 A	12.0 A	6.9 A
2CP 40/180A	26.7 A	15.4 A	8.9 A	26.0 A	15.0 A	8.7 A
2CP 40/200B	-	17.5 A	10.1 A	-	17.5 A	10.1 A
2CP 40/200A	-	20.0 A	11.5 A	-	20.0 A	11.5 A

PALLETIZATION

MODEL		GROUPAGE			CONTAINER				
Single-phase	Three-phase	n° pumps	H (mm)	kg		n° pumps	H (mm)	kg	
				1~	3~			1~	3~
2CPm 25/140H	2CP 25/140H	50	1370	960	930	70	1860	1340	1300
2CPm 160/160	2CP 160/160	50	1540	1240	1180	70	2100	1730	1650
2CPm 25/140M	2CP 25/140M	50	1370	960	930	70	2860	1340	1300
2CPm 25/160B	2CP 25/160B	50	1540	1230	1180	70	2100	1720	1640
-	2CP 25/160A	50	1540	-	1240	70	2100	-	1730
-	2CP 32/200C	18	1420	-	700	24	1840	-	930
-	2CP 32/200B	18	1420	-	790	24	1840	-	1050
-	2CP 32/210B	12	1420	-	670	16	1840	-	880
-	2CP 32/210A	12	1420	-	750	16	1840	-	1000
-	2CP 40/180C	12	1420	-	610	16	1840	-	800
-	2CP 40/180B	12	1420	-	670	16	1840	-	880
-	2CP 40/180A	12	1420	-	740	16	1840	-	980
-	2CP 40/200B	6	1200	-	551	9	1730	-	818
-	2CP 40/200A	6	1200	-	557	9	1730	-	827

