

Centrifugal pumps

High flow rates



PERFORMANCE RANGE

- Flow rate up to **2200 l/min** (132 m³/h)
- Head up to **24.5 m**

APPLICATION LIMITS

- Manometric suction lift up to **7 m**
- Liquid temperature between **-10 °C** and **+90 °C**
- Ambient temperature up to **+40 °C**
- Max. working pressure:
 - **6 bar** for HF 4
 - **10 bar** for HF 6-8-20-30
- Continuous service **S1**

CONSTRUCTION AND SAFETY STANDARDS

EN 60034-1
IEC 60034-1
CEI 2-3



CERTIFICATIONS



INSTALLATION AND USE

Suitable for use in civil and agricultural applications. The high efficiency and continuous duty capabilities makes these pumps ideal for use in activities such as flood and spray irrigation, drawing water from lakes, rivers and wells, or for any number of different industrial applications where the characteristics of high flow rates and mid to low head are required.

The pump should be installed in an enclosed environment, or at least sheltered from inclement weather.

OPTIONALS AVAILABLE ON REQUEST

- Special mechanical seal
- Other voltages or 60 Hz frequency

GUARANTEE

2 years subject to terms and conditions

CHARACTERISTIC CURVES AND PERFORMANCE DATA

50 Hz n= 2900 1/min HS= 0 m

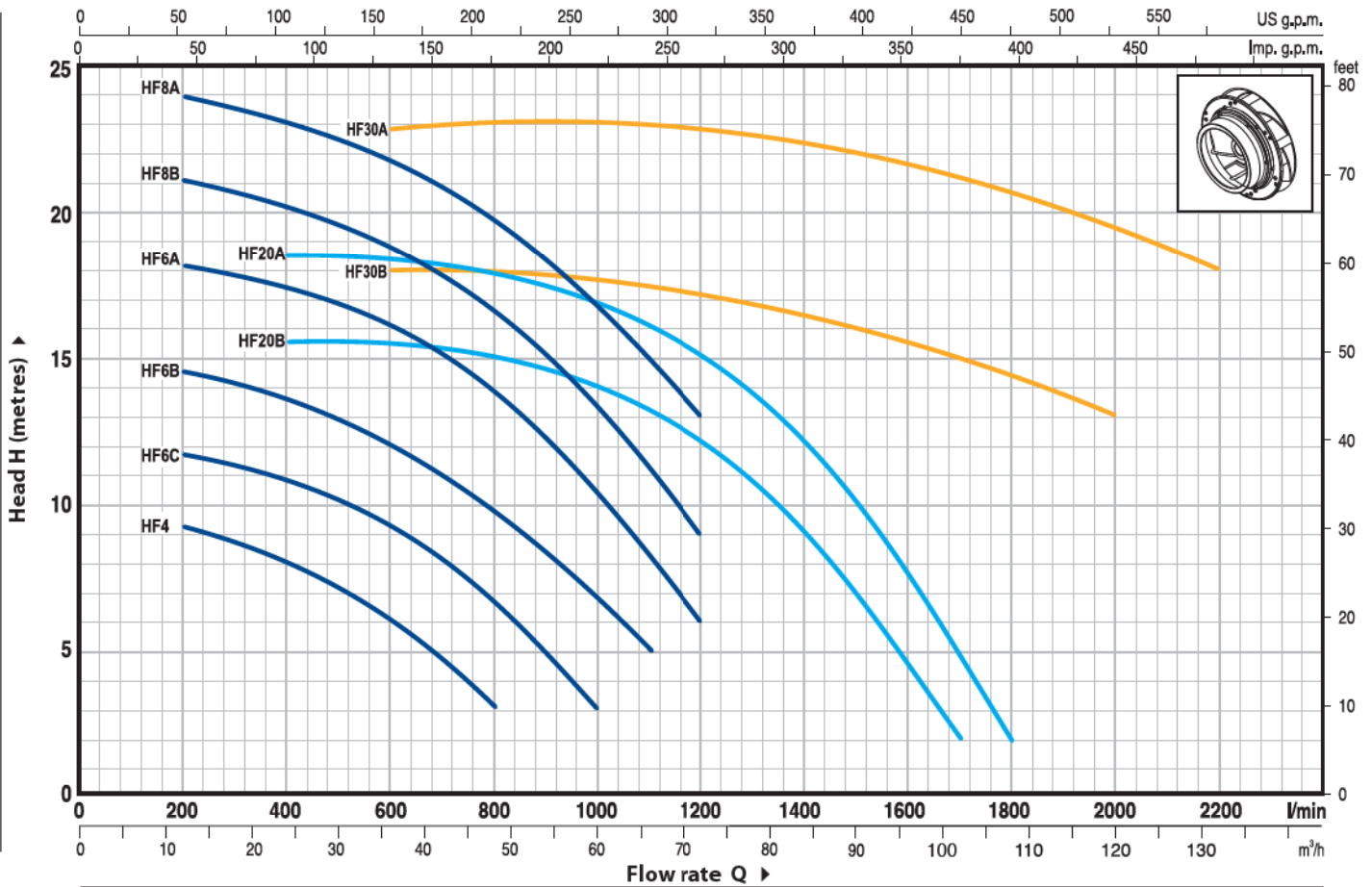

MODEL		POWER		Q	H metres																		
Single-phase	Three-phase	kW	HP		m³/h	0	12	18	24	30	36	42	48	54	60	66	72	84	96	102	108	120	132
				l/min	0	200	300	400	500	600	700	800	900	1000	1100	1200	1400	1600	1700	1800	2000	2200	
HFm 4	HF 4	0.75	1		10	9.3	8.7	8	7	6	4.7	3											
HFm 6C	HF 6C	1.1	1.5		11.9	11.7	11.3	10.7	10.2	9.2	8	6.7	5	3									
HFm 6B	HF 6B	1.5	2		14.7	14.5	14	13.5	12.8	12	11	9.7	8.2	6.7	5								
-	HF 6A	2.2	3		18.5	18.1	17.8	17.2	16.8	16	15	13.8	12.2	10.5	8.3	6							
-	HF 8B	3	4		21.5	21	20.7	20	19.5	18.8	17.8	16.5	15	13.5	11.2	9							
-	HF 8A	4	5.5		24.5	24	23.5	23	22.5	21.8	20.8	19.5	18.3	16.8	15	13							
-	HF 20B	3	4		16	-	-	15.5	15.4	15.3	15.2	15	14.5	14	13	12	9	4.8	2				
-	HF 20A	4	5.5		19	-	-	18.5	18.4	18.3	18.2	18	17.5	17	16.2	15.2	12	7.8	5	2			
-	HF 30B	5.5	7.5		18	-	-	-	-	18	18	18	18	18	17.5	17	16.5	15.5	15	14.5	13		
-	HF 30A	7.5	10		23	-	-	-	-	23	23	23	23	23	22.5	22.5	22.5	22	21.5	21	19.5	18	

Q = Flow rate H = Total manometric head HS = Suction height

Tolerance of characteristic curves in compliance with EN ISO 9906 App. A.

POS.	COMPONENT	CONSTRUCTION CHARACTERISTICS					
1	PUMP BODY	Cast iron, complete with threaded ports in compliance with ISO 228/1					
2	BODY BACKPLATE	Cast iron (stainless steel AISI 304 for HF 4)					
3	IMPELLER	Brass for HF 4, HF 6, HF 8, HF 20 Cast iron for HF 30					
4	MOTOR SHAFT	Stainless steel EN 10088-3 - 1.4104					
5	MECHANICAL SEAL	<i>Pump</i>	<i>Seal</i>	<i>Shaft</i>	<i>Materials</i>		
		<i>Model</i>	<i>Model</i>	<i>Diameter</i>	<i>Stationary ring</i>	<i>Rotational ring</i>	<i>Elastomer</i>
		HF 4	AR-14	Ø 14 mm	Ceramic	Graphite	NBR
		HF 6	FN-18	Ø 18 mm	Graphite	Ceramic	NBR
		HF 8-20	FN-20	Ø 20 mm	Graphite	Ceramic	NBR
HF 30	FN-24	Ø 24 mm	Graphite	Ceramic	NBR		
6	BEARINGS	<i>Pump</i>	<i>Model</i>				
		HF 4	6203 ZZ / 6203 ZZ				
		HF 6	6304 ZZ / 6204 ZZ				
		HF 8B-20B	6206 ZZ - C3 / 6205 ZZ				
		HF 8A-20A	6306 ZZ - C3 / 6206 ZZ - C3				
HF 30	6307 ZZ - C3 / 6206 ZZ - C3						
7	CAPACITOR	<i>Pump</i>	<i>Capacitance</i>				
		<i>Single-phase</i>	<i>(230 V or 240 V)</i>		<i>(110 V)</i>		
		HFm 4	20 µF 450 VL	60 µF 300 VL			
		HFm 6C	31.5 µF 450 VL	60 µF 250 VL			
HFm 6B	45 µF 450 VL	80 µF 250 VL					
8	ELECTRIC MOTOR	<p>HFm: single-phase 230 V - 50 Hz with thermal overload protector built-in to the winding.</p> <p>HF: three-phase 230/400 V - 50 Hz up to 4 kW, 400/690 V - 50 Hz from 5.5 to 7.5 kW</p> <p>➔ Pumps fitted with the three-phase motor option offer IE2 (IEC 60034-30) class high performance</p> <p>- Insulation: F class.</p> <p>- Protection: IP 44.</p>					

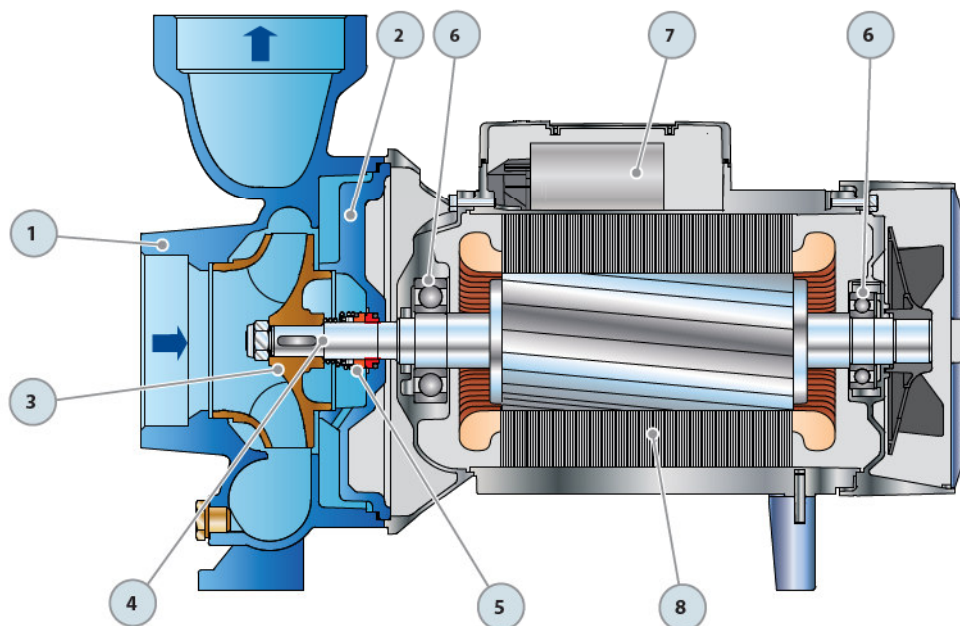

DIMENSIONS AND WEIGHT

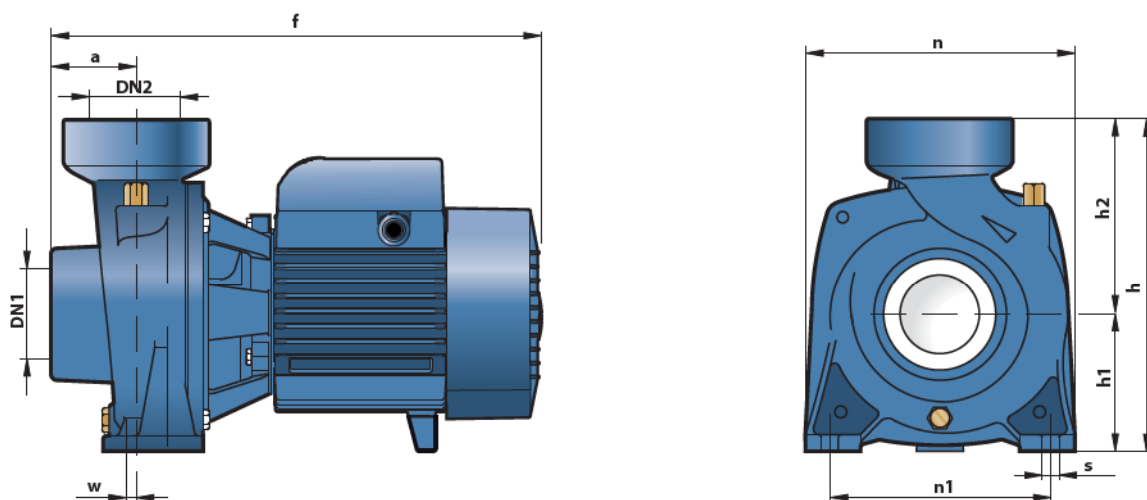

MODEL		PORTS		DIMENSIONS mm									kg	
Single-phase	Three-phase	DN1	DN2	a	f	h	h1	h2	n	n1	w	s	1~	3~
HFm 4	HF 4	2½"	2½"	55	323	240	97	143	198	155	0	10	14.5	13.2
HFm 6C	HF 6C	3"	3"	68	411	312	120	192	240	190	6	12	25.5	24.2
HFm 6B	HF 6B												26.5	25.5
-	HF 6A	4"	4"	80	435	312	132	180	245	190	30	14	-	26.7
-	HF 8B												-	35.0
-	HF 8A												-	40.0
-	HF 20B												-	35.0
-	HF 20A												-	40.0
-	HF 30B	82	585	370	160	210	292	212	-	-	-	-	60.9	
-	HF 30A	-	-	-	-	-	-	-	-	-	-	-	-	65.2

ABSORPTION

MODEL	VOLTAGE (single-phase)		
	230 V	240 V	110 V
Single-phase	230 V	240 V	110 V
HFm 4	5.9 A	5.3 A	11.8 A
HFm 6C	8.8 A	8.0 A	17.6 A
HFm 6B	10.8 A	9.8 A	21.6 A

MODEL	VOLTAGE (three-phase)					
	230 V	400 V	690 V	240 V	415 V	720 V
Three-phase	230 V	400 V	690 V	240 V	415 V	720 V
HF 4	4.3 A	2.5 A	1.4 A	4.0 A	2.3 A	1.3 A
HF 6C	6.2 A	3.6 A	2.1 A	6.0 A	3.5 A	2.0 A
HF 6B	8.0 A	4.6 A	2.7 A	7.4 A	4.3 A	2.5 A
HF 6A	9.0 A	5.2 A	3.0 A	8.3 A	4.8 A	2.8 A
HF 8B	11.8 A	6.8 A	3.9 A	12.1 A	7.0 A	4.0 A
HF 8A	15.8 A	9.1 A	5.3 A	15.2 A	8.8 A	5.1 A
HF 20B	13.0 A	7.5 A	4.3 A	13.4 A	7.7 A	4.4 A
HF 20A	15.2 A	8.8 A	5.1 A	15.3 A	8.8 A	5.1 A
HF 30B	21.3 A	12.3 A	7.1 A	20.4 A	11.8 A	6.8 A
HF 30A	28.6 A	16.5 A	9.5 A	27.5 A	15.9 A	9.2 A

PALLETIZATION

MODEL		GROUPAGE				CONTAINER			
Single-phase	Three-phase	n° pumps	H (mm)	kg		n° pumps	H (mm)	kg	
				1~	3~			1~	3~
HFm 4	HF 4	60	1540	890	830	84	2100	1240	1150
HFm 6C	HF 6C	36	1480	940	890	54	2150	1400	1330
HFm 6B	HF 6B	36	1480	970	940	54	2150	1450	1400
-	HF 6A	36	1480	-	980	54	2150	-	1460
-	HF 8B	18	1430	-	650	24	1860	-	860
-	HF 8A	18	1430	-	740	24	1860	-	980
-	HF 20B	18	1430	-	650	24	1860	-	860
-	HF 20A	18	1430	-	740	24	1860	-	980
-	HF 30B	12	1570	-	750	16	2040	-	990
-	HF 30A	12	1570	-	800	16	2040	-	1060

